

Background document

Tuberculosis Action Plan for the WHO European Region 2023–2030

Draft for the Seventy-second Regional Committee for Europe

Tuberculosis (TB) and drug-resistant TB (DR-TB) continue to represent major public health threats in the World Health Organization (WHO) European Region. The Region has achieved notable progress in reducing overall TB incidence and mortality, though challenges persist in reducing the DR-TB burden and addressing TB/HIV coinfection, which continue to cause premature mortality.

This background document details the Tuberculosis Action Plan for the WHO European Region 2023–2030 and outlines the vision and strategic actions for the TB response in the Region during the period 2023 to 2030. The TB Action Plan has been developed through a Region-wide participatory consultation process with Member States, partners, civil society organizations and affected communities.

The TB Action Plan will support Member States to implement their national responses to the TB epidemic, covering the period after the United Nations General Assembly High-level Meeting on the Fight Against Tuberculosis on 26 September 2018, and provides strategies to allow the Region to reach the global End TB Strategy targets to reduce TB incidence by 80% and TB deaths by 90% by 2030.

The TB Action Plan 2023–2030 builds on the progress and lessons learned from the implementation of the previous Action Plan 2016–2020. The Action Plan strategically combines disease-specific approaches that place people at the heart of the response, in line with the European Programme of Work, 2020–2025 – “United Action for Better Health in Europe”. The TB Action Plan shapes the overall vision of the TB response nested in universal health coverage and is aligned with the resolution on Realizing the Potential of Primary Health Care: Lessons Learned from the COVID-19 Pandemic and Implications for Future Directions in the Region, adopted at the 71st session of the Regional Committee for Europe. By contributing to the core priorities of the European Programme of Work, moving towards attaining UHC, promoting health and well-being and protecting against health emergencies, the Tuberculosis Action Plan for the WHO European Region 2023–2030 strives for a better balance in providing support at the regional, subregional and country levels for greater impact at the population level.

This background document is submitted for consideration and adoption at the 72nd session of the WHO Regional Committee for Europe, together with a draft decision and a working document.

Contents

Abbreviations	4
Executive summary	6
At a glance	7
Background	8
Rationale for the Regional TB Action Plan 2023–2030	8
The Tuberculosis Action Plan for the WHO European Region 2016–2020	9
Regional progress towards the targets of the United Nations General Assembly High-level Meeting on the Fight Against Tuberculosis 2018–2022	10
Impact of the COVID-19 pandemic and the challenges for TB programmes	12
European Programme of Work, 2020–2025	14
Outline of the TB Action Plan for the WHO European Region 2023–2030	16
Epidemiological projections for reaching the TB Action Plan targets	17
Key areas of intervention	19
Pillar 1: Integrated people-centred care and prevention	19
A. People at the centre: a shared approach on partnerships with PHC, public health and civil society and communities for united action	19
B. Comprehensive TB prevention, including programmatic management of TB preventive treatment (PMTPT), infection prevention and control and vaccination against TB	24
C. Systematic screening for TB disease in targeted populations	26
D. Early diagnosis of all forms of TB and universal access to drug-susceptibility testing (DST), including the use of rapid tests	29
E. Equitable access to quality treatment and care for all people with TB, including those with DR-TB and TB comorbidities; and support for patients to facilitate treatment adherence	31
Pillar 2: Bold policies and supportive systems	34
A. Governance and leadership	34
B. Health finance and universal health coverage	34
C. Health workforce including community health workers	35
D. Strategic information and digital health	36
E. Procurement and supply-chain management	36
Pillar 3: Intensified research and innovation	39
Priority actions for Member States	40
Priority actions for WHO and partner organizations	41
Partnerships, accountability and progress monitoring	41
Partnerships	41
Accountability, monitoring and reporting	41
References	43
Annexes	46
Annex 1 Monitoring and evaluation framework	46

Annex 2 Mathematical modelling to inform and track progress on reaching the TB Action Plan targets 61

Model structure	61
Model equations	62
Model calibrations	64
Model interventions.....	67

Abbreviations

aDSM	active drug-safety monitoring and management
BCG	bacille Calmette-Guérin (vaccine)
COVID-19	coronavirus disease 2019
CRG	communities, rights and gender
CSO	civil society organization
DAT	digital adherence technology
DNO	diagnostic network optimization
DR	drug-resistant
DS	drug-susceptible
DR-TB	drug-resistant tuberculosis
DST	drug-susceptibility testing
ECDC	European Centre for Disease Prevention and Control
EECA	eastern Europe and central Asia
ELI	European Laboratory Initiative on TB, HIV and Viral Hepatitis
EPW	European Programme of Work, 2020–2025
ERI-TB	European Tuberculosis Research Initiative
EU	European Union
GDO	geographically dispersed office
GPW 13	Thirteenth General Programme of Work, 2019–2023
HPC	high-priority countries
HRG	human rights and gender
IPC	infection prevention and control
LIMS	laboratory information management systems
MAF-TB	Multisectoral Accountability Framework to accelerate progress to End TB
MDR-TB	multidrug-resistant tuberculosis
mSTR	modified fully oral shorter treatment regimens
mWRD	molecular WHO-recommended rapid diagnostic test
NCD	noncommunicable diseases
NGO	nongovernmental organization
NSP	National Strategic Plan (for TB)
NTP	National Tuberculosis Programme
PHC	primary health care
PLHIV	people living with HIV
PMTPT	programmatic management of tuberculosis preventive treatment
PSM	procurement and supply management
RCC-THV	Regional Collaborating Committee on Accelerated Response to Tuberculosis, HIV and Viral Hepatitis

rGLC	regional Green Light Committee
RR-TB	rifampicin-resistant tuberculosis
SCRC	Standing Committee of the Regional Committee for Europe
SDG	Sustainable Development Goal
TAG-TB	Technical Advisory Group on Tuberculosis
TB	tuberculosis
TB-REP	Tuberculosis Regional Eastern European and Central Asian Project
TBI	tuberculosis infection
TPT	tuberculosis preventive treatment
UHC	universal health coverage
UN	United Nations
UNHLM	United Nations High-Level Meeting
USAID	United States Agency for International Development
VST	video-supported treatment
WHO	World Health Organization
XDR-TB	extensively drug-resistant tuberculosis

Executive summary

Tuberculosis (TB) and drug-resistant TB (DR-TB) continue to represent major public health threats and cause premature mortality in the World Health Organization (WHO) European Region. The Region has achieved notable progress in reducing overall TB incidence and mortality, though challenges persist in reducing the DR-TB burden and addressing TB/HIV coinfection.

In 2014, the World Health Assembly adopted the global End TB Strategy (resolution WHA67.1), which included the Sustainable Development Goal (SDG) target 3.3 to end the TB epidemic and the epidemics of other communicable diseases by 2030 (1–3). In 2015, in line with the End TB Strategy, the WHO Regional Office for Europe launched the Tuberculosis Action Plan for the WHO European Region 2016–2020 which was endorsed by the 65th session of the Regional Committee for Europe through resolution EUR/RC65/17 (4). These Regional commitments were reinforced by the Moscow Declaration to End TB (2017) and the political declaration of the United Nations General Assembly High-level Meeting on the Fight Against Tuberculosis, 2018 (UNHLM on TB), with targets set for 2018–2022 (5,6).

At the conclusion of the TB Action Plan 2016–2020, a summary of the final report on progress and the challenges involved was submitted to the 70th session of the WHO Regional Committee for Europe (RC70), along with a proposition of a way to extend the validity of the Action Plan from 2021 to 2030 (7). However, in May 2021, the 15th Meeting of the Technical Advisory Group on Tuberculosis (TAG-TB) recommended the development of a new TB Action Plan for the WHO European Region for 2023–2030 because of the new operational environment for the TB response in the Region (8). The TB Action Plan 2023–2030 will support Member States to implement their national responses to the TB epidemic, covering the post-UN High-Level Meeting period and provides strategies to allow the Region to reach the global End TB Strategy targets to reduce TB incidence by 80% and TB deaths by 90% by 2030 (1). This document outlines the vision and strategic actions for the TB response for the WHO European Region for 2023–2030.

The 2023–2030 TB Action Plan builds on the progress and lessons learned from the implementation of the previous Action Plan. The TB Action Plan strategically combines disease-specific approaches that place people at the heart of the response, in line with the European Programme of Work, 2020–2025 – “United Action for Better Health in Europe” (EPW), and universal health coverage (UHC) aligned to realize the potential of primary health care (9). By contributing to the core priorities of the EPW, moving towards attaining UHC, promoting health and well-being and protecting against health emergencies, the Regional TB Action Plan strives for a better balance of support at the regional, subregional and country levels for a greater impact at the population level.

The TB Action Plan has been developed through a Region-wide participatory consultation process with Member States, partners, civil society organizations and affected communities. The summary version of the Regional Action Plan – the working document – will be submitted to the 72nd session of the Regional Committee for Europe for endorsement together with a draft decision and a background document containing the full version of the plan.

At a glance

TB Action Plan for the WHO European Region for 2023–2030:

Vision:	A Region free of the TB burden by 2030
Goal:	To end the spread of drug-susceptible and drug-resistant TB by achieving universal access to prevention, diagnosis and treatment in all Member States of the Region
Regional targets by 2030:	90% reduction in TB deaths compared with 2015 80% reduction in TB incidence compared with 2015 85% treatment success rate of MDR/RR-TB patients
Regional milestones by 2025:	75% reduction in TB deaths compared with 2015 50% reduction in TB incidence compared with 2015 80% treatment success rate of MDR/RR-TB patients
Key areas of intervention:	<p>Pillar 1. Integrated people-centred care and prevention</p> <p>A. People at the centre: a shared approach on partnerships with PHC, public health, civil society and affected communities for united action.</p> <p>B. Comprehensive TB prevention, including programmatic management of TPT, infection prevention and control and vaccination against TB.</p> <p>C. Systematic screening for TB disease among contact people, high risk groups and other people who are vulnerable or in vulnerable situations.</p> <p>D. Early diagnosis of all forms of TB and universal access to drug-susceptibility testing (DST), including the use of rapid tests.</p> <p>E. Equitable access to quality treatment and care for all people with TB, including those with DR-TB and TB comorbidities; and support for patients to facilitate treatment adherence.</p> <p>Pillar 2. Bold policies and supportive systems</p> <p>A. Governance and leadership</p> <p>B. Health financing and universal health coverage</p> <p>C. Health workforce including community health workers</p> <p>D. Strategic information and digital health</p> <p>E. Procurement and supply management.</p> <p>Pillar 3. Intensified research and innovation</p> <p>A. Rapid uptake of new technologies (diagnostics, regimens, vaccine) and new tools, interventions and strategies</p> <p>B. Research to optimize implementation and impact, and promote innovations.</p>

Background

Rationale for the Regional TB Action Plan 2023–2030

Tuberculosis (TB), drug-resistant TB (DR-TB) and TB/HIV coinfection continue to pose a major burden on public health in the World Health Organization (WHO) European Region. The majority of Member States in western Europe are making good progress towards TB elimination, but other Member States in eastern part of the Region continue to experience high burdens of DR-TB. Countries of eastern Europe and central Asia (EECA) are home to 24% of the global cases of multidrug-resistant or rifampicin-resistant TB (MDR/RR-TB) and 47% of the pre-extensively DR-TB cases (pre-XDR-TB). The proportions of MDR/RR-TB cases detected among new and previously treated patients with TB significantly exceed the global average, with MDR/RR-TB accounting for 18% of newly diagnosed individuals and 53% of previously treated individuals. In 2020, there were an estimated 69 000 new cases of MDR/RR-TB, with an estimated 37 000 MDR/RR-TB cases among the pulmonary TB cases. In addition, TB/HIV coinfection is on the rise in the WHO European Region, with an estimated HIV infection rate of 12% among incident TB cases in 2020 (29 000 people with TB/HIV coinfection) compared with 9.7% in 2015 (10).

Since 2015, the WHO European Region has achieved notable progress in reducing overall TB incidence and mortality and has been the WHO Region with the fastest decline in TB incidence (11).¹ These successes have been achieved due to strong political commitment and funding, improved access to the WHO-recommended rapid molecular diagnosis for TB, strengthened testing quality, the transition to fully oral treatment regimens for both TB and DR-TB, and the expansion of the use of the integrated people-centred model of TB care (12). Now, new technologies – including new diagnostics, fully oral medicines for DR-TB treatment, digital health solutions and innovative service-delivery approaches – are reshaping the response to TB faster than ever.

However, multiple health and structural factors that increase exposure and vulnerability to TB are affecting the pace of progress, including HIV infection; diabetes mellitus and other noncommunicable diseases (NCD); tobacco, alcohol and drug use; mental health disorders; poverty; undernutrition; unemployment; imprisonment; and migration. Often, system-level challenges and inefficiencies limit the resources that are available to prevent and fight TB, and contribute to the disease burden in the Region. These issues include, but are not limited to, continued high rates of hospital admissions that are not clinically indicated, extended stays in settings with potentially poor administrative and engineering infection control measures, and limited access to the complete range of WHO-recommended regimens for TB and DR-TB.

The coronavirus disease 2019 (COVID-19) pandemic has severely affected the progress made in the Region towards reaching the TB targets as, from 2020, pandemic responses have led to service disruptions and barriers in accessing care, resulting in substantial reductions in the numbers of both TB notifications and people being enrolled onto treatment, especially for MDR/RR-TB, in the Region. WHO modelling scenarios have demonstrated that even a temporary 25–50% decrease in the number of TB notifications over a 3-month period because of the impact of the COVID-19 pandemic could lead to significant increases in the numbers of TB deaths, which could potentially reverse the progress achieved since 2015 (10,13).

In addition, the war in Ukraine has triggered an escalating humanitarian crisis that may have a serious impact on progress towards regional targets TB. The war is having devastating direct and indirect impacts on people's lives and health and the functioning of health system. The discontinuation of treatment and care due to disruption to health services and shortages of medical supplies poses a severe risk of increased mortality and morbidity from communicable diseases, such as HIV and tuberculosis. The risk of infectious diseases has increased and population movement exacerbates this risk globally, including an increased risk of the spread of HIV and multidrug-resistant tuberculosis due to the conflict's effect on long-term care.

¹In 2015, in line with the global End TB Strategy, the WHO Regional Office for Europe (WHO/Europe) launched the Tuberculosis Action Plan for the WHO European Region 2016–2020 (resolution EUR/RC65/R6).

Addressing the immediate health challenges in Ukraine and ensuring the continuity of TB and DR-TB treatment and complete health service for refugees in Europe, is an immediate priority. However, medium- and long-term efforts will be needed to support the recovery in Ukraine, the surrounding countries and the Region at large.

While new options for TB prevention, diagnosis, treatment and service delivery provide opportunities to accelerate the TB response, the Region's national health systems are still recovering from the setbacks caused by the COVID-19 pandemic, and more challenges are anticipated due to the humanitarian crisis in Europe. The forecasted economic impact across the Region may affect governments' budgetary abilities to fund the ambitious commitments needed to scale-up the TB response in other countries in the Region (14). This new reality calls for revitalized political commitments, renewed financial commitments and an agile and fit-for-purpose response to TB to get the TB response back on track from the anticipated loss in progress towards ending TB in the Region.

To reinforce Region-specific efforts to reduce TB incidence by 90% by 2030 (1), the new Tuberculosis Action Plan for the WHO European Region 2023–2030 defines the priorities for Member States in this new operating context and reflects the urgency to get back on track to meet the End TB Strategy targets. The TB Action Plan defines the strategic actions for the Region up until 2030. These strategic actions are aligned with the End TB Strategy; the European Programme of Work, 2020–2025 – “United Action for Better Health in Europe”; the reinvention of primary health care (PHC) in the post-COVID-19 era; and the regional action plans for HIV, viral hepatitis and sexually transmitted infections 2023–2030. This Action Plan covers the period subsequent to that covered by the political declaration of the United Nations General Assembly High-level Meeting on the Fight Against Tuberculosis (2018–2022).

The TB Action Plan has been developed by the WHO Regional Office for Europe (hereinafter referred to as the Regional Office) to support Member States to implement their national TB responses and fulfil their commitments to tackle TB. It will ensure universal access to quality TB prevention, diagnosis, treatment and care. A task force led by the Regional Office has developed a comprehensive monitoring and evaluation framework to document the progress of the implementation of the TB Action Plan (Annex 1). In 2025, the progress towards reaching the global and regional targets will be reviewed and any necessary adjustments will be applied to the TB Action Plan.

The Tuberculosis Action Plan for the WHO European Region 2016–2020

The TB Action Plan for the WHO European Region 2016–2020 (4) was launched to implement the targets of the End TB Strategy (1) in the Region. The initial End TB Strategy milestones should have been reached by 2020, which was the final year covered by the previous TB Action Plan for 2016–2020, with a target of a 35% reduction in the number of TB deaths by 2020 compared with 2015 levels. However, the target was not reached, and the actual reduction in absolute number of TB deaths in 2020 compared with 2015 was only 26% (Fig. 1). An increase in the number of deaths has been observed in HIV-positive TB cases during 2019–2020.

The WHO European Region set a target of a 25% reduction in TB incidence by 2020 compared with 2015 levels, which was more ambitious than the End TB Strategy global milestone of a 20% reduction. The cumulative reduction in the TB incidence rate from 2015 to 2020 was 25%, meaning that the Region exceeded the End TB Strategy 2020 milestone and reached the TB Action Plan's target for 2016–2020 (Fig. 1).

Fig. 1 Progress made towards the targets of the TB Action Plan for the WHO European Region 2016–2020

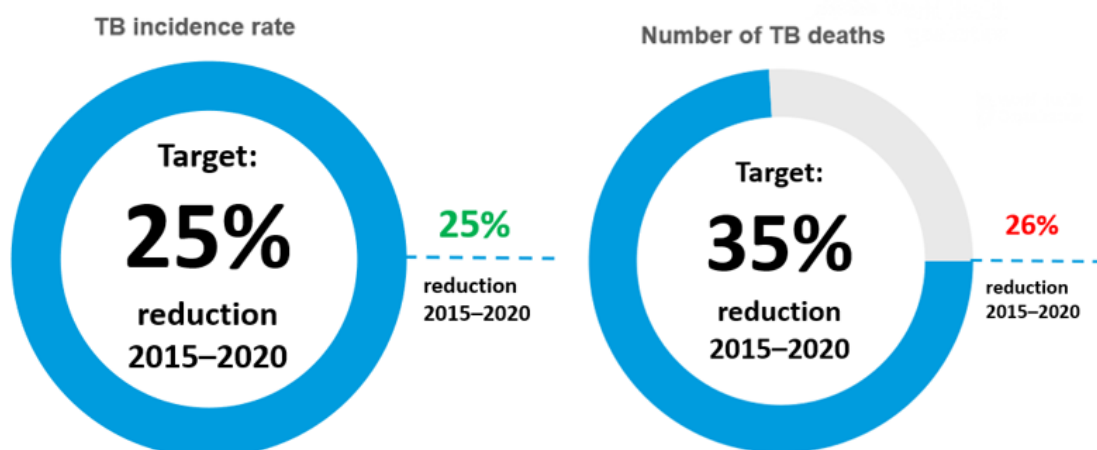

Source: WHO Global tuberculosis report 2021

Although the Region currently has the fastest global decline in TB incidence and mortality, it also has the highest rates of DR-TB. According to the Global TB Report 2021, treatment success rates have plateaued at around 75% for drug-susceptible TB (DS-TB) and 56% for MDR/RR-TB (15). Nevertheless, good progress has been reported for treatment success rates for MDR/RR-TB cases with additional resistance to fluoroquinolones (pre-XDR-TB),² with a 51% treatment success rate for the 2018 cohort compared with the 35% success rate reported for the 2015 cohort. This was made possible by the gradual increase in access to bedaquiline-containing treatment regimens and other new TB medications, which this cohort of patients primarily benefited from. The scale-up of the coverage with WHO-recommended fully oral treatment regimens for MDR/RR-TB under programmatic and operational research conditions is expected to significantly increase treatment success rates for the 2019 cohort and for future cohorts. Nonetheless, the impact of the COVID-19 pandemic on detection, delayed diagnosis and enrolment onto treatment for MDR/RR-TB, together with as yet suboptimal treatment coverage with the WHO-recommended fully oral treatment regimens, might hamper progress in reaching the regional target (10,11).

Regional progress towards the targets of the United Nations General Assembly High-level Meeting on the Fight Against Tuberculosis 2018–2022

In September 2018, the UN General Assembly held its first-ever High-level Meeting on the Fight Against Tuberculosis, which was attended by heads of state and government, and other leaders. The outcome of the meeting was a political declaration in which the commitments to the Sustainable Development Goals (SDGs) and the End TB Strategy were reaffirmed and new commitments added. For the first time, global targets were set for funding to be mobilized for TB prevention, care and research, and for the numbers of people receiving treatment for TB infection and disease (6). The global progress by 2020 on implementing these targets is shown in Fig. 2.

² Definition of extensively drug-resistant TB (XDR-TB) used before 2021.

Fig. 2 Global progress made on the implementation of the UNHLM on TB targets, 2018–2020

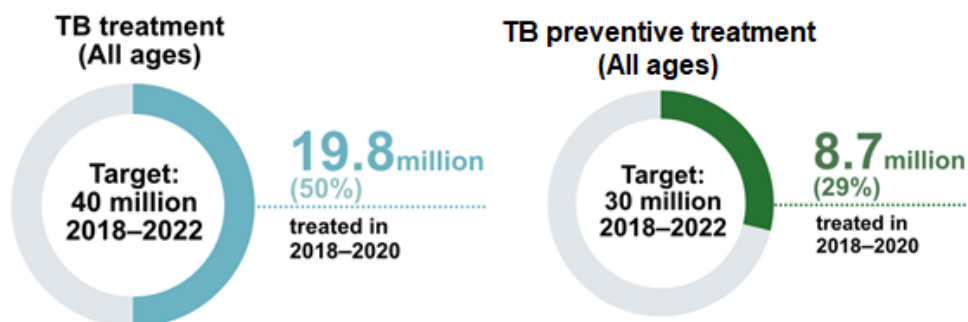

Source: WHO Global tuberculosis report 2021

The Region’s share of the TB preventive treatment (TPT) target set by the UNHLM is approximately 2 million people receiving TPT over the 5 years. The progress made during 2018–2020 fell short of the target due to a combination of factors, including programmatic components, funding, concerns about the risks of drug toxicity and generating drug resistance, access and availability of testing and TPT regimen components, and the impact of the COVID-19 pandemic. So far, the majority of people who have been provided with TPT have been household contacts (over 5 years of age) of a notified individual with TB. However, for people living with HIV (PLHIV), the level of TPT coverage is considerably lower, and substantial intensification and expansion of efforts and investments are required to improve the provision of TPT in this target group (Fig. 3).

Fig. 3 Regional progress towards the UNHLM targets: numbers of people receiving TB preventive treatment, 2018–2020

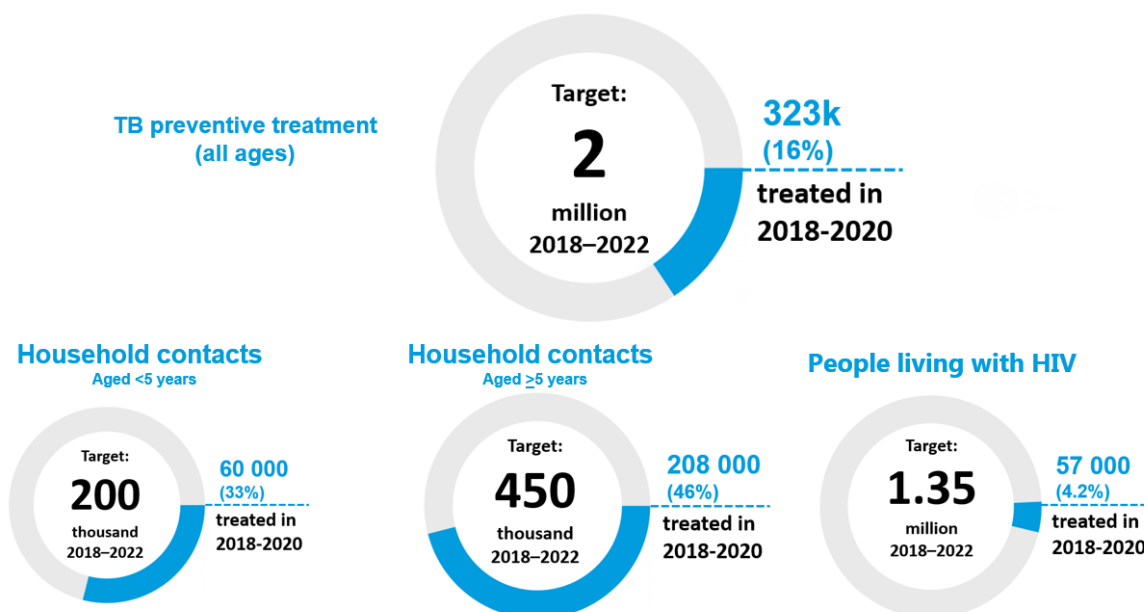

Source: WHO Global tuberculosis report 2021

The UNHLM target of 1.23 million people being enrolled onto TB treatment during 2018–2022 is not likely to be reached in full because of the impact of the COVID-19 pandemic on TB notifications and treatment enrolment, particularly for MDR/RR-TB cases. The scale-up of rapid TB diagnosis, the continual transition to fully oral regimens for TB and MDR/RR-TB, the introduction of innovative approaches to treatment and care under programmatic and operational research conditions, and the scale-up of the provision of community-based models of care will contribute to bringing the Region close to the 2018–2022 target of universal coverage with TB treatment, including for MDR/RR-TB.

Fig. 4 Regional progress towards the UNHLM targets: the number of people treated for TB, 2018–2020

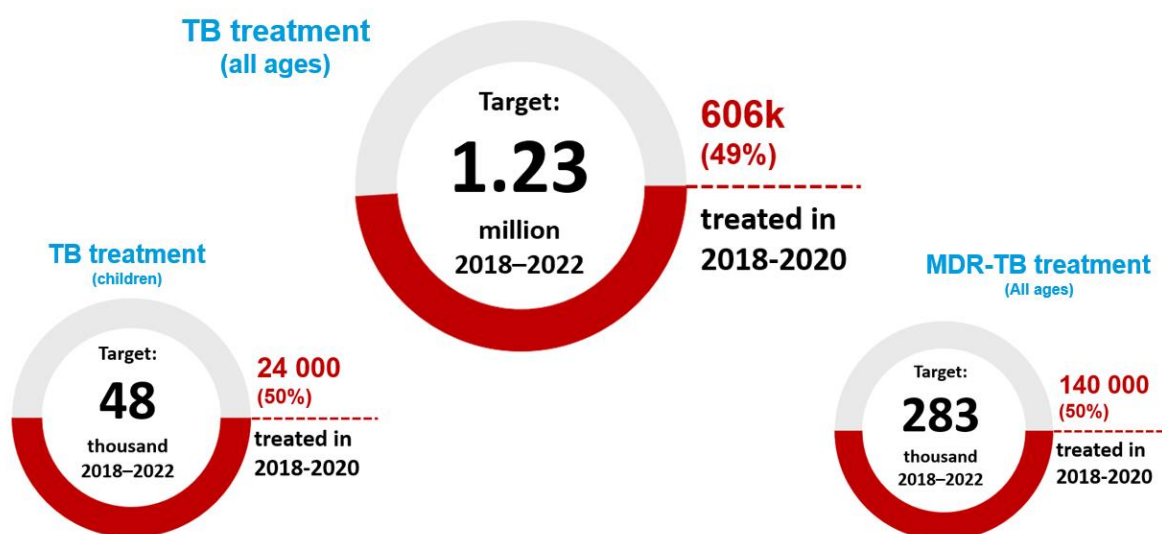

Source: WHO Global tuberculosis report 2021

The UNHLM also set targets for: ending TB stigma and discrimination; removing legal barriers to universal access to quality TB prevention and care; and promoting a rights-based, equitable and gender-sensitive TB response. Progress made towards these targets includes: the Declaration of the Rights of People Affected by TB in 2019 (16), national and regional assessments of human rights and gender (HRG) barriers, engagement of politicians to promote laws that protect the rights of people with TB, stronger engagement of civil society in the TB response, and stronger regional and national networks of civil society and communities and affected by TB. A report produced by the Stop TB Partnership on the progress made towards the UN political declaration targets has identified further progress and key community asks (17).

Impact of the COVID-19 pandemic and the challenges for TB programmes

Globally, the COVID-19 pandemic has had enormous impacts on health and the social and economic aspects of people’s lives; impacts which have also been felt in the Region’s Member States. The pandemic has put health and social systems under considerable pressure, causing additional challenges for health and well-being across the Region, with pivotal implications for the individuals and communities affected by TB. The pandemic severely affected the progress made towards the TB targets, as a result of the service disruptions and barriers in accessing care, which led to substantial reductions in TB notifications and treatment enrolment, especially for MDR/RR-TB cases. Case notifications decreased by 24% in 2020 compared with 2019, and TB-related mortality increased by 5% in 2020 as a result of the first increase in HIV-positive TB deaths recorded in over two decades (11).

The impact of the pandemic was most acute in 2020 when countries introduced strict public health and social measures to curb the spread of the virus. These restrictions limited the movements of both health care providers and those who needed care. A survey conducted by the Regional Office observed a 36% decrease in TB notifications between April and June 2020 compared with the same period in 2019, with a correlation between the stringency of domestic movement restrictions and the decrease in TB notifications (18). Sixteen countries accounted for over 90% of the decrease in TB notifications in the Region, with four countries, Romania, the Russian Federation, Ukraine and Uzbekistan, accounting for almost 60% of the reduction (19).

The pandemic response has increased the inequities in the access to services that were already present prior to the pandemic and has aggravated economic hardship – both of which are factors that seriously impact TB patients. The existing barriers were exacerbated and new barriers have emerged, particularly

for the key and vulnerable populations for TB. The pandemic response also put tremendous strains on health services, including TB services. Health staff who used to work for TB programmes have been redeployed and the capacities of the TB and HIV diagnostic networks have been used to tackle COVID-19. Restoration of services after the lifting of the restrictions has been slow and suboptimal in many countries, and multiple COVID-19 waves have made service restoration challenging.

COVID-19 has accentuated the vulnerabilities of both health and social services and exposed the reality that these services are often underfunded (19). Even though the breakthroughs in testing and the availability of COVID-19 vaccines will enable the Region to transition towards a steady state of low-level COVID-19 transmission, the post-pandemic legacy will be problematic (10,13).

Despite these difficulties, the COVID-19 crisis has set in motion profound transformations in service integration and multisectoral response, and these transformations will be applied to accelerating efforts to achieve the regional TB targets. To ensure the continuity of essential TB services during and beyond the pandemic, WHO has issued a policy and technical guidance for service integration (20–22). WHO calls on Member States to implement the key actions needed for catch-up and recovery, which include:

- limiting transmission of TB and COVID-19 in congregate settings and health care facilities by ensuring basic infection prevention and control measures for health staff and patients, cough etiquette and patient triage;
- leveraging the expertise and experience of the national tuberculosis programmes (NTPs), including implementation research, especially for rapid testing, contact investigation and provision of TPT, by building synergies with the COVID-19 response efforts;
- promoting people-centred and community-based TB care in preference to hospital treatment, except for serious clinical indications, and using the WHO-recommended, fully oral TB treatment regimens;
- maximizing remote care and support for people with TB as well as building up NTP capacities by expanding the use of digital technologies;
- providing bidirectional screening and testing for TB and COVID-19 for individuals when indicated, and leveraging TB laboratory networks and platforms where necessary;
- leveraging community-led monitoring initiatives for identifying and addressing barriers to access, including linking them to real-time surveillance systems; and
- ensuring proactive planning and budgeting for TB and COVID-19 (including during the catch-up phase), procurement of supplies and risk management.

The expected impact of the setback caused by the pandemic is high. As described earlier, WHO modelling anticipates the impact of this setback to be high, with significant increases in TB incidence and mortality predicted (13). Additional efforts need to be put in place to prevent the number of people developing TB and dying from the disease being worse in 2022 (10). An immediate priority in the Region must be to restore access to essential TB services so that the rate at which the End TB Strategy 2025 milestones are being achieved can be brought back on track and then accelerated.

European Programme of Work, 2020–2025

The European Programme of Work, 2020–2025 – “United Action for Better Health in Europe” (EPW) was submitted for adoption at the 70th session of the Regional Committee in September 2020 (9). The EPW has three core priorities: moving towards UHC; protecting people better against health emergencies; and ensuring healthy lives and well-being for all at all ages (Box 1). These core priorities constitute the pillars of the Thirteenth General Programme of Work, 2019–2023 (GPW 13) that all global WHO Member States have committed to implement. They are anchored in the 2030 SDG targets and are linked to GPW 13’s three bold targets for the health sector’s contribution to the SDGs: the triple billion targets. The EPW also outlined four flagship initiatives to complement the core priorities: the Pan-European Mental Health Coalition; Empowerment through Digital Health; the European Immunization Agenda 2030; and Healthier behaviours: incorporating behavioural and cultural insights. The targets of the TB Action Plan have been mapped against the EPW core priorities and flagship initiatives.

Box 1 The Core Priorities of the European Programme of Work, 2020–2025

1) Moving towards universal health coverage

The Regional Office will support the efforts of Member States to build robust, resilient and evidence-informed systems, as the core of the post-COVID-19 recovery, with a focus on five areas:

- a) putting people at the centre of services;
- b) ensuring and enhancing financial protection;
- c) facing the post-COVID-19 recovery health workforce challenges;
- d) ensuring access for all to medicines, vaccines and health products;
- e) improving governance and stewardship.

2) Protecting people better against health emergencies

The COVID-19 crisis has been – and still is – a transformative experience for the Regional Office. This crisis has led to a triple agenda for prolonged health emergencies.

- a) Learn lessons: expand the ongoing in-action review of the COVID-19 crisis into a formal review of the Region’s response to recent health emergencies;
- b) Support country preparedness and response capacity;
- c) Reinforce regional preparedness and capacity to respond, and produce the public goods required to manage crises.

3) Ensuring healthy lives and well-being for all at all ages

The actions for prevention and the promotion of health and well-being require programmes with a visible commitment to dedicated and specific public health efforts. These efforts include:

- a) supporting local living environments that enable health and well-being;
- b) promoting safer, healthier and better lives;
- c) improving patient safety and tackling antimicrobial resistance;
- d) developing strategic intelligence on levels and inequalities of health and well-being;
- e) reviewing major well-established programmes within the Regional Office’s technical portfolio, and assessing their need for improved efficiency through innovation in terms of digitalization, technology and organization.

The WHO European Region has the capacity and the prerequisites necessary to further accelerate reductions in TB mortality and incidence by ensuring universal access to high-quality prevention, diagnosis, treatment and care for people with TB and DR-TB in all Member States in alignment with the EPW. The TB Action Plan shapes the overall vision of nesting the TB response in UHC and aligning it with the resolution on Realizing the Potential of Primary Health Care: Lessons Learned from the COVID-19 Pandemic and Implications for Future Directions in the Region, adopted at the 71st session of the Regional Committee (23). In alignment with the EPW core priority to ensure healthy lives and well-being

for all at all ages – and alongside moving towards UHC, promoting health and well-being and protecting against health emergencies – the Regional Office will apply a two-pronged approach to TB prevention and care by both striving for a better balance of support at regional, subregional and country levels, and providing enhanced support direct to Member States to enable a greater impact to be made at the population level.

The TB Action Plan will contribute to moving towards UHC by focusing on the introduction of essential TB service packages at the PHC level; reducing financial barriers for key populations, aiming for zero catastrophic costs; and removing financial and geographical barriers to care and the barriers related to gender, human rights, stigma and discrimination. The TB Action Plan will accelerate progress towards realizing the potential of PHC by strengthening the role of primary care and multidisciplinary delivery networks addressing the physical and mental health, and the social well-being, of people affected by TB. Furthermore, an effective regional TB response that improves service delivery; strengthens the health workforce and health financing; improves diagnostic networks, and product and supply management; and improves data systems will contribute to more robust health systems.

The contribution of the TB Action Plan to the EPW will be measured by specific TB indicators and targets to be achieved initially by 2025, as a midpoint milestone, followed by targets for 2030, which will contribute to the global End TB Strategy targets. The EPW measurement framework includes a specific target for TB of an 80% treatment success rate for MDR/RR-TB by 2025, which is aligned with SDG target 3.3 and the milestone of the new TB Action Plan. The TB Action Plan will also contribute to the implementation of the four EPW flagship initiatives through their joint priorities and the cross-references with other regional strategies. Additional emphasis will be placed on regaining the progress lost due to the COVID-19 pandemic, protecting gains during health emergencies, and being better prepared for maintaining essential TB services during emergency situations.

Outline of the TB Action Plan for the WHO European Region 2023–2030

Vision

The vision of the Regional TB Action Plan is a Region free of the TB burden by 2030.

The TB Action Plan is fully aligned with the End TB Strategy and its three pillars: Pillar 1 – integrated, patient-centred care and prevention; Pillar 2 – bold policies and supportive systems; Pillar 3 – intensified research and innovation (1). The TB Action Plan has the same vision and is designed to achieve the same goals, but, in addition, outlines an implementation framework for achieving these goals that is contextualized to the regional context. The TB Action Plan capitalizes on the synergies and actions presented in the new Regional Action Plan for HIV/Hepatitis and Sexually Transmitted Infections (STIS) 2022–2030 to address the overlapping burdens of HIV and TB and to ensure linkages with other regional strategic documents. The TB Action Plan is linked with the Digital Health Action Plan for the WHO European Region 2023–2030 to support countries to leverage and scale-up digital transformations for better health and to align digital technology investment decisions with the needs of their health systems.

To advance the agendas for UHC and PHC (23), the TB Action Plan will focus on essential TB service packages for use at the PHC level and to prioritize key populations, leaving no one behind, in direct alignment with the EPW 2020–2025 (9). WHO will strive to balance the provision of support at the regional, subregional and country levels with providing enhanced country support direct to Member States to achieve a greater impact at the population level. The TB Action Plan draws on EPW flagship initiatives, including the Mental Health Coalition, the Empowerment through Digital Health, the Immunization 2030 Agenda and Healthier choices: incorporating behavioural and cultural insights, into the provision of TB services.

Goal

The goal is to end the spread of DS-TB and DR-TB by achieving universal access to prevention, diagnosis and treatment in all Member States of the Region, thereby contributing to the End TB Strategy goal of ending the TB epidemic. Universal access means evidence-based practices and quality services that are available, accessible, affordable and acceptable to everyone and to all communities, enshrining access to health care as a basic right through approaches that protect and promote equity, ethics, gender equality and human rights (9).

Regional targets by 2030

The targets for 2030 are to achieve (compared with 2015 levels):

- 90% reduction in TB deaths;
- 80% reduction in TB incidence; and
- 85% treatment success in the MDR/RR-TB patient cohort.

Regional milestones (to be achieved by 2025)

The targets for 2025 are to achieve (compared with 2015 levels):

- 75% reduction in TB deaths;
- 50% reduction in TB incidence; and
- 80% treatment success in the MDR/RR-TB patient cohort.

Key areas of intervention

The key areas of intervention of the TB Action Plan for the WHO European Region 2023–2030 are given in Table 1.

Table 1. TB Action Plan for the WHO European Region 2023–2030

Areas	Interventions
1. Integrated people-centred care and prevention	<p>A. People at the centre: a shared approach on partnerships with PHC, public health, civil society and affected communities for united action.</p> <p>B. Comprehensive TB prevention, including programmatic management of TPT, infection prevention and control and vaccination against TB.</p> <p>C. Systematic screening for TB disease among contact people, high risk groups and other people who are vulnerable or in vulnerable situations.</p> <p>D. Early diagnosis of all forms of TB and universal access to drug-susceptibility testing (DST), including the use of rapid tests.</p> <p>E. Equitable access to quality treatment and care for all people with TB, including those with DR-TB and TB comorbidities; and support for patients to facilitate treatment adherence.</p>
2. Bold policies and supportive systems	<p>A. Governance and leadership</p> <p>B. Health financing and universal health coverage</p> <p>C. Health workforce including community health workers</p> <p>D. Strategic information and digital health</p> <p>E. Procurement and supply management.</p>
3. Intensified research and innovation	<p>A. Rapid uptake of new technologies (diagnostics, regimens, vaccine) and new tools, interventions and strategies</p> <p>B. Research to optimize implementation and impact, and promote innovations.</p>

Note: Areas of intervention are based on the three End TB Strategy pillars (24).

Epidemiological projections for reaching the TB Action Plan targets

Mathematical modelling and scenario simulations were carried out as epidemiological projections to inform and track the progress made towards reaching the TB Action Plan targets for the Region.

A TB transmission model was designed to capture the natural history of disease and the TB cascade of care. This model was calibrated with the regional data from WHO's data collection system. Full details of the mathematical modelling can be found in **Annex 2**. In brief, these projections consist of three intervention periods, namely:

- 2016–2020: improvements towards universal health coverage;
- 2021–2025: rollout of innovative interventions/tools;
- 2027–2030: introduction of so-called silver bullet measures (i.e. effective vaccination).

Within this framework, the incidence and mortality of TB are projected until 2035 (Figs. 5 and 6) and incidence reductions are compared against WHO's TB elimination threshold. Please note that the disruptions in TB detection and treatment as a result of the COVID-19 pandemic are introduced in 2020–2021.

Fig. 5 Projected TB incidence in the Region, 2016–2035

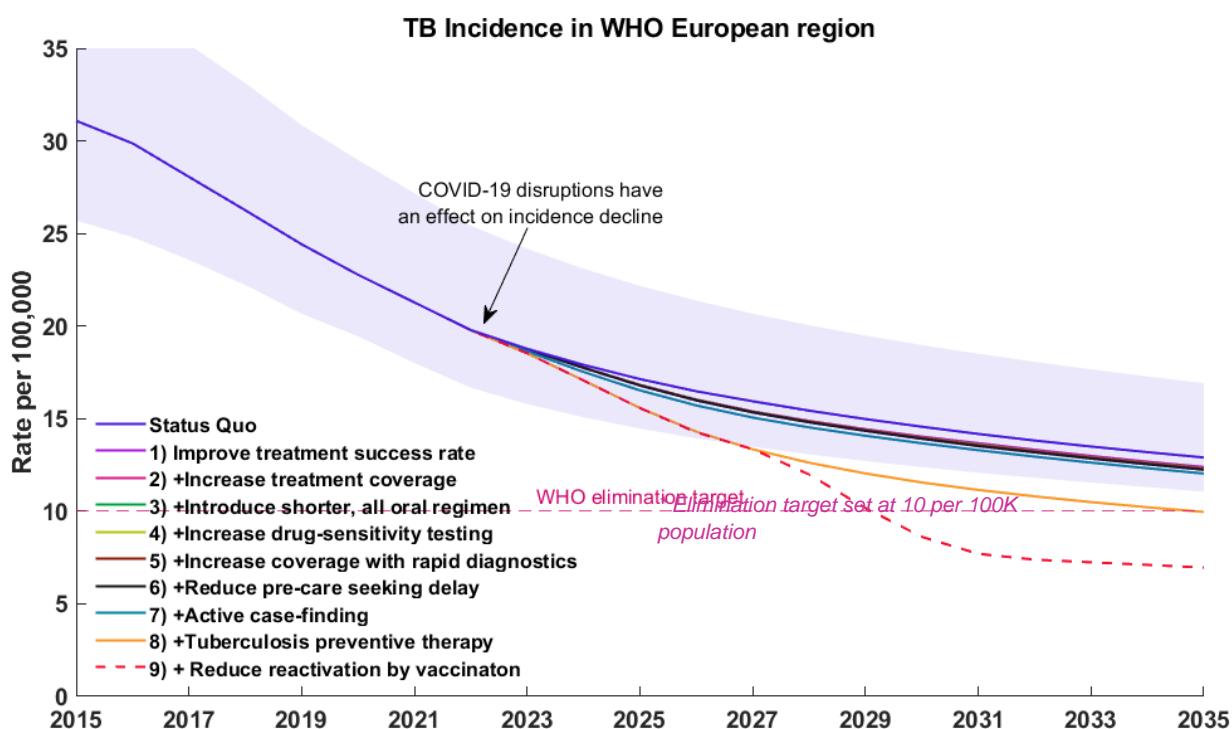

Note: The simulated interventions are introduced cumulatively (i.e. “+TPT” displays the effect of interventions 1 to 8). All trajectories show the median value of the posterior sample; the uncertainty band shows the 95% credible interval for the status quo.

These modelling projections show that a steady pace of TB incidence reduction reaches an inflection point at the time of the COVID-19 disruptions (2021–2022), resulting in a deceleration in the projected path of reduction. The model projects the effects of a package of new tools sequentially putting into place, starting from 2021, to assess the individual contributions of specific interventions to the overall effect on incidence. These trajectories suggest that it would be possible to regain the path of incidence reductions towards elimination by adding the important efforts of TPT. In these projections, the target could be reached by 2034. If an effective TB vaccination becomes available and is widely distributed, starting in 2027, the reduction could be accelerated and the target could be reached by 2029. **Annex 2** includes descriptions of the individual interventions and the scenario design.

The projected number of TB deaths for the same package of simulated interventions (Fig. 6), show a similar pattern of reductions as described in Fig. 5, with the exception of “Active case-finding”, which suggests that it could result in early mortality reductions.

Fig. 6 Projected annual number of TB deaths in the Region, 2016–2035

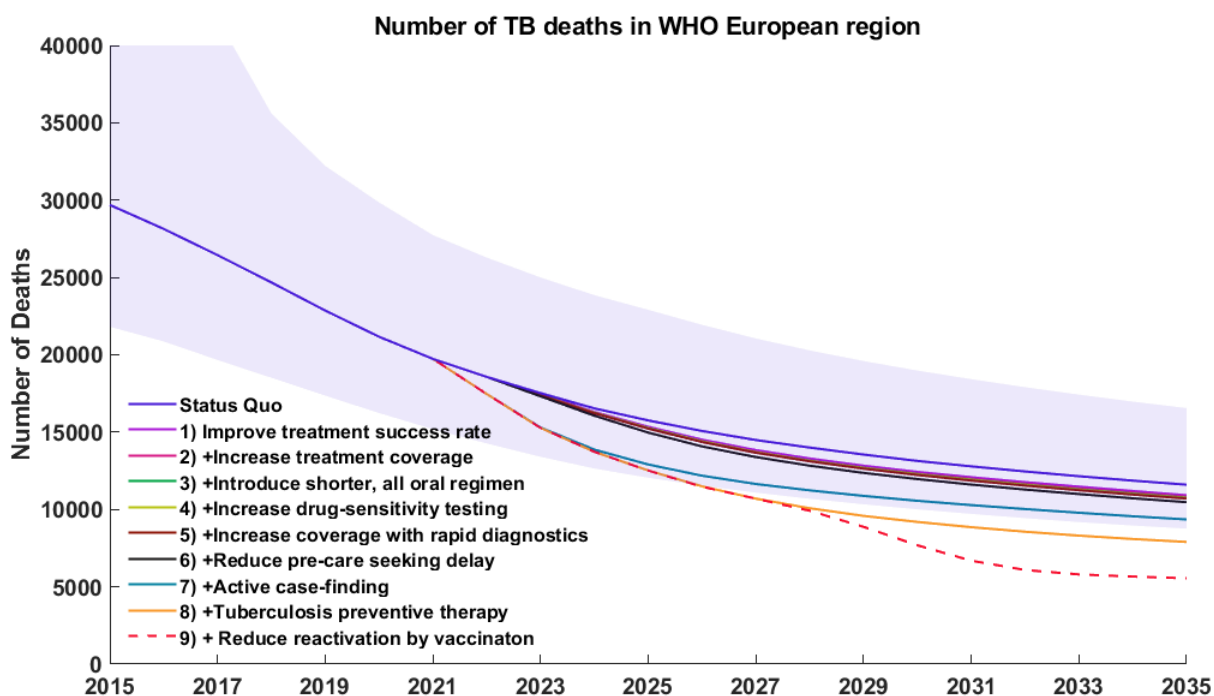

Note: The simulated interventions are introduced cumulatively (i.e. “+TPT” displays the effect of interventions 1 to 8). All trajectories show the median value of the posterior sample; the uncertainty band shows the 95% credible interval for the status quo.

Key areas of intervention

Pillar 1: Integrated people-centred care and prevention

Putting people at the centre of efforts for TB care and prevention is part of the first pillar of the End TB Strategy and the first of the core priorities of the EPW. Integrated people-centred care and prevention for TB entails using a shared approach for partnerships with PHC, public health and communities; making care accessible for key, vulnerable and underserved populations; and having equitable and human-rights based approaches for providing care.

A. People at the centre: a shared approach on partnerships with PHC, public health and civil society and communities for united action

People-centred health systems prioritize the needs of individuals, their families and communities, both as participants and beneficiaries of high-quality comprehensive and coordinated services delivered in an equitable manner and which involve people as partners in decision-making (25,26). Consistent with the Astana Declaration (on Primary Health Care, 2018), strengthening the role of PHC in the delivery of TB services is critical to developing inclusive, effective and efficient health care services.

TB services across the continuum of care should be available for all with no discrimination, including children and adults, men and women, the urban and rural poor, people deprived of liberty, and people with limited access to health services, such as migrants, and undocumented and uninsured populations. For all forms of DS-TB and DR-TB, care should primarily be provided in outpatient settings rather than in hospitals, with stronger roles for PHC, and community- or home-based care rather than facility-based treatment. Full access to specialized care should be available for people: with complications; who are seriously ill or have severe adverse events; who are suffering from mental health disorders or substance addiction; or who have uncontrolled comorbidities. Supportive services including social and psychological support should be an integral part of people-centred services.

The main priority areas include:

- promoting a shared approach based on partnerships of TB programmes with PHC, public health and civil society and communities for united action;
- reaching key, vulnerable and underserved populations;
- protecting and promoting equity, ethics, gender equality and human rights in addressing TB.

Promote a shared approach based on partnerships with PHC, public health and civil society and communities for united action

Moving towards effective care for people with TB and DR-TB requires the support of multidisciplinary models of service delivery, acceptance of people-centred practices, cooperation between different care providers, enhanced clinical skills and high levels of staff motivation (23).

During 2016–2021, the Region’s Member States prioritized the implementation of people-centred approaches. The progress made has included countries adopting people-centred models of care as part of their policies and strategies and working towards ambulatory-based care, with higher participation rates in communities, especially in the countries that are engaged in the multi-partner Tuberculosis Regional Eastern European and Central Asian Project (TB-REP) on strengthening health systems for effective TB and DR-TB control (27,28). However, progress on reducing unnecessary hospital stays for TB has been slower than anticipated. The documented effectiveness of community-based TB activities and the substantial efforts that have been expended by Member States and all partners at national and international level in recent years will serve as a strong background for united action between NTPs, nongovernmental organizations (NGOs) and community-based organizations to ensure people-centred care for people and families affected by TB.

The COVID pandemic, and other health and humanitarian emergencies, highlights the importance of making health services, including TB, prepared for emergencies; resilient, to allow them to continue essential service operations; and able to recover quickly.

With the new technologies available, it is possible to further accelerate progress towards people-centred models of care and to reduce unnecessary hospital stays. Adopting models predominantly based on outpatient services, strengthening diagnostic networks, engaging general health services through multidisciplinary approaches, reducing the use of hospital stays to only cases with specific clinical criteria, and encouraging stronger community engagement is imperative (23). The focus on the integration of the TB, HIV and viral hepatitis services will continue within the framework of the UN Common Position on Ending HIV, TB and Viral Hepatitis through Intersectoral Collaboration, depending on country context (29,30).

A UHC approach also requires a shift towards a stronger role for community-based supportive services. To support this programme area, civil society partners, jointly with the Regional Office, have developed the *Standardized package of community-based supportive services to improve TB outcomes* (31). Sustainable finance for community action will ensure the benefit of community contributions to achieving quality services. Joint strategic planning, and monitoring and evaluation should become the norm and measurements of the impact of community-based TB activities based on standard indicators will be routinely reported.

Reaching key, vulnerable and underserved populations

TB is strongly associated with health-related factors that weaken the immune system (including HIV infection; diabetes mellitus and other noncommunicable diseases (NCD); and tobacco, alcohol and drug use), and with the social, economic and environmental determinants that increase exposure and vulnerability to TB (such as poverty, unemployment, deprivation of liberty and migration). This means that growing inequities with insufficient social protections contribute to the TB burden, and the COVID-19 response has exacerbated the inequities and inequalities in the TB response. The most disadvantaged and overlooked people in our societies were more likely to have suffered the greatest consequences from the pandemic and are now in need of focused and comprehensive interventions. Nosocomial transmission, especially in closed facilities and congregate settings, is one factor contributing to the TB epidemic in the Region.

One issue facing countries in the Region is the variable accessibility of care for key populations and the most vulnerable populations due to the various structural barriers and complicated patient pathways to accessing the comprehensive services they need. This results in individuals being lost from the health services as they move through care pathways. For example, migrants diagnosed with DR-TB often do not have access to second-line treatment because of the lack of cross-border agreements, information exchange protocols and funding mechanisms (32). Key and vulnerable populations are not consistently prioritized in many countries in the Region. Additionally, national commitments to allocating funding for community-based approaches to reach these unreached populations are very variable. Concerted actions are needed to gather evidence on key and vulnerable populations in each country and to reach these people with services they need.

Protect and promote equity, ethics, gender equality and human rights in addressing TB

Removing structural barriers is at the core of the strategies outlined to ensure the achievement of the End TB Strategy targets. By signing the political declaration approved at the UNHLM on TB, the heads and representatives of Member States committed to “protect and promote equity, ethics, gender equality and human rights in addressing tuberculosis” (6). The right to health, articulated as the highest attainable standard of physical and mental health, is a fundamental right of every human being, and is enshrined in the WHO Constitution (33,34). Social justice, ethical principles and values underpin the End TB Strategy (1). In this context, equity reflects social justice when the distribution of advantages and burdens among people is fair. Ethics are concerns about what should or should not be done and includes consideration of our actions, intentions and habits. Human rights are legal guarantees that protect individuals and groups against actions that interfere with their fundamental freedoms and human dignity, while establishing entitlements requires positive actions.

A regional overview has identified that the most prevalent and persistent barriers to care for key and vulnerable populations are stigma and discrimination; gender-related barriers for women, such as lower autonomy in decision-making including financial decision-making, lack of family support and gender-based violence related to TB; and financial and geographical barriers to access. These barriers are prevalent in people who are accessing care before a diagnosis has been established. In some countries, extended hospitalizations of children with TB, placing children in residential settings for extended periods, and the isolation of children from families leads to family disruptions, social exclusion, developmental delays and poor quality schooling (35).

There is an urgent need to eliminate health disparities and remove the barriers to accessing services to make the TB response rights-based, equitable and stigma-free, with communities at its centre. There should be further focus on increasing TB awareness in communities, using civil society engagement to increase TB awareness and care and community-led monitoring, building legal literacy among TB stakeholders, engaging legal service providers to promote enabling legal environments, and investment in capacity-building for community systems and advocacy.

Priority actions for Member States

These priority actions are to be deployed by countries with respect to their health priorities, national legislation and context.

Priority actions	Timeline
1. Adopt the definition of people-centred services and the models of care into their policies, including in clinical practice guidelines.	Immediately
2. Transition to integrated people-centred services by formalizing the roles and responsibilities of all providers in TB prevention and care, including PHC and community-based services. Continue to reduce unnecessary hospital admissions and stays in line with clinical criteria.	By 2025
3. Ensure meaningful engagement of civil society and affected communities and scale-up community-based TB services through direct and social contracting mechanisms and funding for strengthening community systems.	Ongoing

4. Adopt and implement WHO's <i>Standardized package of community-based services to improve TB treatment outcomes</i> .	By 2025
5. Ensure the inclusion of standardized indicators for community-based engagement and ensure regular reporting.	By 2025
6. Identify, document, assess risks and prioritize key and vulnerable populations and the gaps in essential services in the TB care cascade.	By 2025
7. Provide comprehensive supportive services to all in need, especially key and vulnerable populations – people with certain conditions (such as HIV, mental health disorders, diabetes mellitus, and other NCDs); people deprived of liberty; migrants and displaced people; national minorities and indigenous population groups; people with alcohol- and/or drug-use; children and elderly people), including those who are not in PHC catchment areas, thus preventing catastrophic costs.	Ongoing
8. Further improve the continuity of TB care between the penitentiary and civilian sectors, with a particular focus on countries transitioning from external to domestic funding.	Ongoing
9. Remove the barriers to quality TB prevention, diagnosis, treatment and care for mobile populations (migrants, refugees and internally displaced people) and ensure cross-border continuity of care, especially during emergency situations, through cross-border action, intergovernmental agreements and multisectoral approaches.	By 2027
10. Identify, monitor and report stigma and human rights and gender barriers that prevent at-risk, key and vulnerable populations from having equitable access to TB care and prevention, including through community engagement and community-led monitoring. Based on the assessment results, communities, rights and gender (CRG)-specific actions should be incorporated in national strategic plans (NSPs) and put into practice.	By 2025
11. Ensure national laws, and strategic and technical policies are consistent with the principles of human rights and social justice, prohibit stigma and discrimination against people with TB and key and vulnerable populations, are gender-responsive, and protect the privacy, confidentiality and access to information for people affected by TB.	By 2025
12. Ensure mechanisms for the promotion and protection of human rights and ethical principles as part of social protection measures to support effective TB prevention and care, including capacity-building, legal support and accountability mechanisms.	Ongoing
13. Develop and implement comprehensive programmes to reduce stigma-related barriers to TB care and prevention, prioritizing the work with health care workers, local public authorities and affected communities.	By 2025

Priority actions for WHO and partner organizations

Priority actions	Timeline
1. Strengthen the work towards UHC and the promotion of people-centred care by cross-divisional work towards the provision of comprehensive essential clinical service packages at the PHC and outpatient specialist levels and a standardized package of community-based supportive services.	Ongoing
2. Promote and support meaningful engagement of civil society and affected communities in all components of the TB response, including the scale-up of community-based TB services, governance and community-led monitoring. Encourage sustained funding of civil society organization (CSO)-led core programme areas and capacity-building.	Ongoing

3. Continue monitoring the levels of hospital admissions and the average length of stay, including the percentage of people who receive their TB treatment in outpatient settings starting from the point of treatment initiation.	Ongoing
4. Support Member States to address/remove barriers to care, stigma and discrimination in the provision of TB care and prevention through powerful engagement of all relevant stakeholders using regional and global mechanisms, e.g., the Secretariat-led Regional Collaboration Committee on Tuberculosis, HIV and Viral Hepatitis (RCC-THV) and the Civil Society Task Force (CSTF).	Ongoing
5. Develop a mechanism to provide comprehensive supportive services and social protection to all people in need affected by TB using behavioural and cultural insights, and support Member States to transcribe the latest WHO policy guidance into the regional and country context.	By 2025
6. Support Member States to address barriers to quality TB prevention, diagnosis, treatment and care for mobile populations (migrants, refugees and internally displaced people) and ensure cross-border continuity of care especially during emergency situations.	Ongoing

B. Comprehensive TB prevention, including programmatic management of TB preventive treatment (PMTPT), infection prevention and control and vaccination against TB

Programmatic management of TB preventive treatment (PMTPT)

TPT is the main health care intervention available to reduce the risk of TB infection progressing to active TB disease (36). The guidelines provided by WHO and the European Centre for Disease Control (ECDC) consider appropriate TB infection management as a top priority for TB elimination, particularly for population groups who are at the highest risk of TB infection and of progression from infection to disease, including PLHIV and people of all ages who were in contact with patients with pulmonary TB.

In countries approaching TB elimination, additional at-risk groups should also undergo systematic TB infection testing and treatment, such as migrants, refugees who have come from TB endemic areas, people deprived of liberty, health care workers, homeless people, and people who use drugs. Additional at-risk groups may be considered depending on the TB burden in specific settings (37). It is critical to address TPT among people of all ages who were in contact with DR-TB patients either through programmatic implementation or operational research.

Providing TPT to enable the targets to be reached will require a massive scale-up of efforts and larger investment. This includes revising approaches to targeted systematic screening for TB disease and testing for TB infection, better linkages between TB and HIV services to expand TPT coverage for PLHIV and people who were in contact with a patient with TB, and increased access to shorter fully oral and effective TPT regimens, including the newer therapies.

In order to speed up TB elimination, WHO will support Member States with the introduction and scale-up of TPT through the uptake and national operationalization of the latest WHO policy guidance on TB prevention (36). To accelerate the progress towards TB elimination in the Region, the scale-up TPT will require significant joint efforts from Member States, WHO, partners and CSOs. This becomes more relevant given the disruptions in TB care delivery, supply chains and other programme activities as a result of the pandemic and the current humanitarian crisis, highlighting the urgency of immediate actions (38). WHO will lead the implementation of regional operational research initiatives on managing contacts with DR-TB to decrease the gap in evidence and contribute to the development of new WHO policy guidance relevant for settings with high burden of DR-TB, and further rapid uptake of the new WHO recommendations.

It is important to ensure that surveillance, early detection and treatment of TB disease, and infection control measures are effectively implemented, particularly for populations in congregate settings. These are essential prerequisites in deciding on the implementation of TPT services in such populations. Without the implementation of good measures for airborne infection control, the sustained benefits from TPT may be jeopardized due to the high risk of reinfection (36).

Airborne infection prevention and control

COVID-19 has highlighted the importance of interrupting the chain of transmission for infection prevention and control (IPC) of respiratory diseases. The risk of getting TB, or other airborne infections, such as COVID-19, is higher in crowded and inadequately ventilated spaces where infected people spend long periods in close proximity. These environments are where airborne pathogens spread more efficiently by respiratory droplets or aerosols, so taking precautions is extremely important (20). To further reduce the risk of nosocomial transmission of TB, unnecessary and prolonged hospitalizations of patients with TB should be avoided, unless for specific clinical indications, especially in settings with inadequate implementation of administrative and engineering of infection control measures.

Multimodal implementation strategies are core components of effective IPC programmes, according to the *WHO guidelines on tuberculosis infection prevention and control* (39). At its core, a multimodal implementation approach/strategy supports the translation of guideline recommendations into practice within health care settings at the national, facility and community levels, with a view to changing the behaviours both of health care workers and the people seeking health care services. The multimodal implementation strategy consists of several elements implemented in an integrated way to guide

actions and provide the people implementing the multimodal strategy with a clear focus. Unimodal targeting is highly likely to result in failure.

Intensified systematic screening for TB disease, including through the integrated bilateral TB/COVID-19 screening and testing during the pandemic, and the early identification of people with presumed TB are vitally important (21). Health system diagnostic delays will be minimized only by adopting the WHO-recommended diagnostic and treatment algorithms and using the molecular WHO-recommended rapid diagnostic tests (mWRDs). A comprehensive approach focused on the rapid diagnosis of TB, quality identification of drug resistance, proper triage and timely referrals to enable the early initiation of appropriate treatment has been proved to be effective in substantially reducing and breaking the chain of infection transmission.

BCG vaccination in high-prevalence settings

The BCG (bacille Calmette-Guérin) vaccine remains the only licensed vaccine against TB. It provides moderate protection against severe forms of TB in infants and young children. In countries or settings with a high incidence of TB, a single dose of BCG vaccine should be given to all healthy neonates at birth for TB prevention. Countries with low incidence rates for TB may choose to vaccinate neonates selectively in groups at high risk for TB. Countries with declining rates of TB are encouraged to evaluate the epidemiology of TB periodically and consider whether a switch from universal vaccination to selective risk-group vaccination would be appropriate (40). Repeated BCG vaccination (revaccination) in children and BCG vaccination of adults has no proven benefits and therefore should not be performed.

Priority actions for Member States

These priority actions are to be deployed by countries with respect to their health priorities, national legislation and context.

Priority actions	Timeline
1. Programmatic management of TB preventive treatment (PMTPT)	
1.1. Adopt the national guidelines and implement the most up to date WHO recommendations on TB infection (TBI) diagnosis and TPT.	By 2024
1.2. Expand TPT coverage among PLHIV and people who have been in contact with TB patients (both children and adults) to reach the milestones by 2025.	By 2025
1.3. Specify strategies and mechanisms to enable effective enrolment, adherence and completion of TPT among at-risk and vulnerable populations.	
1.4. Specify strategies and mechanisms to continue the integration of people-centred systems and services as a means of improving access to TPT, with particular focus on service delivery in PHC, UHC and health security commitments (high-priority countries).	By 2025
1.5. Engage CSOs and communities in the TB prevention cascade of care, with a particular focus on vulnerable populations.	By 2025
1.6. Strengthen the coordination between sectors and the accountability of all sectors to support and scale-up TPT by applying a multisectoral accountability approach.	
1.7. Plan and implement the gradual transition of TPT services from external to domestic funding. <i>Note: this is relevant to countries that benefit from external funding.</i>	
1.8. Continue ensuring the availability of supervised and continual training for PHC providers, including e-learning and coaching, to support the scale-up of TPT.	By 2024
1.9. Ensure universal access to WHO-recommended TPT options to all people in need.	By 2025
1.10. Review and update NSPs based on the assessment of the TB prevention cascade of care and contextually grounded evidence on inequities in access to services.	By 2025
1.11. With technical support from WHO, standardize and implement the TBI surveillance and response monitoring system at the country level.	By 2025
2. Airborne infection prevention and control	

Priority actions	Timeline
2.1. Ensure that the core components of IPC programmes are implemented at the national level and that TB infection prevention and control practices are integrated in local and national IPC programmes.	Ongoing
2.2. Ensure that all health care facilities serving people with TB and/or presumed TB implement the latest <i>WHO guidelines on tuberculosis infection prevention and control</i> .	
2.3. Continue to ensure supervised and continuous training on TB prevention with increased usage of e-learning methods, and coaching and support for health care staff in airborne infection prevention and control.	
2.4. Allocate additional human and financial resources to ensure the maintenance of IPC equipment in all health care settings.	
3. Vaccination against TB	
3.1. Ensure that WHO policy recommendations on BCG vaccination for infants are implemented and BCG revaccination is discontinued.	By 2025

Priority actions for WHO and partner organizations

Priority actions	Timeline
1. Programmatic management of TPT	
1.1. Produce expanded guidance and tools and recommendations of best practice for financing community and civil society involvement in the TB response, with the aim of strengthening inclusion, effectiveness and sustainability.	By 2025
1.2. Establish and manage a regional hub of expertise on PMTPT to provide tailored technical support to Member States.	By 2024
1.3. Support Member States in the uptake and use of the WHO's Global Benchmarking Tool to evaluate the barriers and bottlenecks to the successful rollout of PMTPT.	Ongoing
1.5. Support Member States in PMTPT planning and forecasting the needs for procurement of the TPT regimens recommended by WHO.	
1.6. Provide tailored support to Member States on the development of TBI surveillance and response monitoring systems.	By 2025
1.7. Support the uptake of the latest WHO recommendations on PMTPT through capacity-building, national policy dialogue, advocacy, communication and sharing best practices.	Ongoing
2. Airborne infection prevention and control	
2.1. Support Member States with the uptake of the latest WHO policy guidance on IPC.	Ongoing
2.2. Support Member States on implementing airborne infection prevention and control through technical assistance, including missions to sustain the capacities of engineers trained on IPC and to promote their engagement at the regional level.	

C. Systematic screening for TB disease in targeted populations

The aim of systematic screening (or active TB case-finding) is to detect TB disease early to minimize avoidable delays in diagnosis and initiation of treatment, thereby reducing the risk of unfavourable treatment outcomes, health sequelae, and the adverse social and economic consequences of TB for individuals and their families. In addition, screening reduces TB transmission in households, workplaces, schools or other community settings by removing people with prevalent disease and shortening the duration of infectiousness. This reduces the incidence of TB infection and consequently the incidence and prevalence of TB disease. The implementation of effective algorithms for screening and diagnostic testing, integrated with PMTPT for people with elevated risk of progression to active TB, will accelerate efforts towards TB elimination (36,41).

The role of screening for TB in overall TB care is extremely important – to address the gaps in case detection, to find missing people with TB, to reach the most vulnerable population groups, and to initiate TPT in a timely manner. Detecting TB *only* in people who present to health facilities is not sufficient to find all people with TB disease. The remaining case-detection gap, particularly in certain population groups at high risk of TB, and the persistence of diagnostic delays, is leading to continued transmission of infection in communities, and indicates the need for more active approaches for detecting TB early and supporting triage for the initiation of appropriate treatment (41–43). The End TB Strategy includes systematic screening for TB disease in high-risk population groups as a central component of the first pillar to ensure early diagnosis of all persons with TB (1).

To fill the gaps in the timely detection of TB during the COVID-19 pandemic, Member States are being supported to provide targeted systematic screening for TB disease and TB contact-investigation mechanisms (21). The introduction of digital health solutions and new technologies, for example artificial intelligence, will support measures for the active finding of missing TB cases, especially during and after the pandemic. Meaningful engagement of civil society and affected communities in active TB case-finding, including in the use of innovations, is instrumental to accelerating efforts towards TB elimination.

Priority actions for Member States

These priority actions are to be deployed by countries with respect to their health priorities, national legislation and context.

Priority actions	Timeline
1. Ensure that all eligible vulnerable and at-risk populations are identified and covered with systematic screening for TB disease.	By 2025
2. Expand the use of digital health technologies to support TB screening and preventive treatment initiatives.	Ongoing
3. Ensure adequate outreach services for key, at-risk and underserved populations are available in the national health care system.	By 2025
4. Include demand creation interventions for TB screening and prevention in a standard package of services provided for key populations.	By 2025
5. Develop or update the national guidelines on the systematic screening for TB disease, including targeted screening algorithms for further integration into the national response to TB.	Ongoing
6. Establish a national mechanism to ensure universal coverage with TPT and systematic screening for TB disease among key populations.	
7. Ensure that systematic screening for TB disease is included into NSPs for TB and supported with sustainable funding. High-priority countries for TB should ensure adequate investments into access to mobile and portable digital solutions for screening of TB diseases, e.g., automatic interpretation of digital chest radiography.	By 2025
8. Provide key populations with a maximum package of TB and HIV detection services in one place with IPC considerations and, where relevant, integrate TB screening tools into other health interventions, including those for COVID-19.	Ongoing
9. Ensure that PHC providers are fully capable of managing systematic screening for TB disease, including its planning, implementation and monitoring, through ongoing training and supervision.	Ongoing
10. Strengthen national capacities to capture data on TB screening and the preventive treatment cascade.	By 2025
11. Ensure that national approaches to screening for TB disease reflect the latest WHO policy guidance and target vulnerable and high TB risk populations.	By 2027
16. Member States should evaluate their TB programmes focused on migrants to ensure that TB screening and testing are balanced with a comprehensive TB care service package.	Ongoing

Priority actions for WHO and partner organizations

Priority actions	Timeline
1. Provide technical assistance to Member States and promote contact investigation and linkages to TPT at regional and national levels, promoting gender equality and human rights.	By 2025
2. Support the development of standardized requirements for digital health technologies to support TB screening and prevention programmes.	Ongoing
3. Support Member States in developing and implementing targeted communication campaigns for key populations.	By 2025
4. Continue to update Member States on the new recommendations and tools for systematic TB screening.	Ongoing
5. Provide tailored support to countries for the development of integrated screening and testing programmes.	
6. Provide technical support to Member States on the integration of TB screening tools into other health interventions (including for COVID-19).	Ongoing
7. Support Member States to project targets of systematic screening for TB disease.	During the next round of strategic planning
8. Establish and support a regional hub of expertise on the systematic screening for TB disease to provide technical support to Member States.	By 2024
9. Collect and publish good practice recommendations for the implementation of TB screening in the Region.	Ongoing
10. Support Member States in their capacity to capture the TB screening and preventive treatment cascade.	By 2025
11. Support Member States with the introduction of digital health solutions and tools to support systematic screening for TB disease.	Ongoing
12. Support Member States in mitigating the impact of COVID-19 on TB services and conduct operational and implementation research on the introduction of innovations and the lessons learned from the COVID-19 response.	By 2024
14. Lead or facilitate the framework of the European Tuberculosis Research Initiative (ERI-TB) for (multi)country research into effectiveness, cost-effectiveness and the behavioural and biosocial issues of the TB screening programmes.	By 2027

D. Early diagnosis of all forms of TB and universal access to drug-susceptibility testing (DST), including the use of rapid tests

Delayed diagnosis of TB and DR-TB, and the consequent late initiation of appropriate therapy, is a major factor leading to poor treatment outcomes and ongoing transmission. mWRD methods are recommended as the initial diagnostic tools used for TB and DR-TB (44). TB programmes require differentiated laboratory and diagnostic networks in which different levels use complementary tools. To increase the access to rapid molecular diagnostic tools and decrease the turn-around time from sample collection to result, especially in settings with moderate-to-high TB incidence, priority should be given to decentralization either by placing mWRDs at peripheral health centres or connecting settings, via efficient sample referral systems and sample transport mechanisms, with the closest mWRD site. Universal DST for all, using molecular techniques for the rapid detection of resistance to all medications used for the treatment of TB and DR-TB and ensuring reliable access close to the point-of-care, should be prioritized and implemented. In low-burden settings, access for vulnerable groups (high-risk groups and remote settings) must be ensured, which will help reduce the time to diagnosis confirmation and lead to timely initiation of appropriate treatment, which will decrease the risk of developing unfavourable treatment outcomes and save lives.

WHO will develop guidance integrated approaches to rapid diagnoses using multidisease platforms for testing for TB, HIV, viral hepatitis and other diseases, such as COVID-19, close to the point-of-care in order to enable the timely diagnosis, treatment initiation of coinfections and prevent further transmission.

Through its regional mechanisms, such as the European Laboratory Initiative on TB, HIV and Viral Hepatitis (ELI), rGLC, and in partnership with WHO collaborating centres, supranational reference laboratories and key stakeholders, WHO will provide state-of-the-art technical assistance to countries to scale-up access to rapid diagnostic testing for TB and DR-TB.

Priority actions for Member States

These priority actions are to be deployed by countries with respect to their health priorities, national legislation and context.

Priority actions	Timeline
1. Use mWRDs for initial diagnostic testing for all people with presumed TB and discontinue the use of microscopy as an initial diagnostic test for TB.	By 2025
2. Make use of the updated WHO recommendations for diagnosis of TB and DR-TB.	
3. Member States that are considered as high-priority countries for TB will assess diagnostic coverage and diagnostic accessibility using patient pathway analysis.	By 2025
4. Scale-up access to diagnostic services for vulnerable populations at increased risk of TB, HIV, viral hepatitis and COVID-19 through an integrated approach that is close to the point-of-care.	
5. Introduce mobile diagnostic services that are integrated with systematic screening for TB disease for those who have limited or no access to health facilities.	By 2025
6. Review and update the TB laboratory and diagnostic network design through diagnostic network assessment and diagnostic network optimization (DNO).	
7. Based on the evidence, and in agreement with the responsible stakeholders, ensure availability and access to WHO-recommended diagnostic platforms and their use up to the maximum potential capacity, including for multidisease testing.	
8. Based on the results of diagnostic network assessments, laboratory assessments and DNOs, update the roles and responsibilities of national TB laboratories and diagnostic networks to enable them to be fully capable of delivering diagnostics based on the updated diagnostic algorithms.	By 2025

Priority actions	Timeline
9. Support the introduction of superordinate, comprehensive, integrating laboratory information management systems (LIMS), based on country-specific needs and which are optimized to the workflow and path of samples through the lab network, and ensure their integration into existing or future health care information systems.	By 2027
10. Ensure the implementation of quality management systems (QMS) within laboratories that provide TB-related diagnostics, based on the evidence provided through external quality assurance assessments.	By 2025
11. Ensure the adequate implementation of biosafety measures, and safe and environmentally friendly waste-disposal mechanisms in the national TB laboratory network.	Ongoing
12. Ensure the uptake and implementation of the WHO-recommended diagnostic technologies, e.g., mWRDs, next generation sequencing and other new diagnostic tools as they are introduced.	Ongoing

Priority actions for WHO and partner organizations

Priority actions	Timeline
1. Continue supporting Member States in strengthening access to quality-assured molecular and phenotypic DST for the treatment of TB and DR-TB as per latest WHO policy guidance.	By 2025
2. Support Member States to scale-up access to diagnostic services for vulnerable populations at increased risk of TB, HIV, viral hepatitis and COVID-19, through an integrated approach and closer to the point-of-care.	By 2025
3. Support Member States in the uptake of the global and regional policy on the use of mobile diagnostic services and methodologies for integrated TB screening and diagnostics.	
4. Support high-priority countries to analyse and optimize their laboratory and diagnostic networks through the introduction of diagnostic network assessment and DNO tools.	By 2025
5. Provide technical support for the introduction, scale-up and use of WHO-recommended platforms with multidisease testing capabilities to address coinfections.	
6. Support building up the national laboratory workforce capacities based on the latest WHO guidelines on TB diagnosis.	Ongoing
7. Support countries to introduce LIMS and to seamlessly integrate it into the existing and future health care information systems.	
8. Support Member States with the introduction of a regional tool for standardized and regular quality assurance assessment that target all tiers of the TB diagnostics network.	By 2025
9. Continue supporting Member States to ensure the biosafety measures necessary for TB laboratory diagnosis, and safe and environment-friendly waste-disposal mechanisms are available across all tiers of the diagnostic network.	Ongoing
10. Continue supporting Member States in the interpretation of current and future rapid diagnostic tests, including sequencing-based technologies, and contribute to strengthening national capacities.	Ongoing
11. Support Member States in developing comprehensive plans that include the reporting and evaluation of new tools and external and internal quality assurance systems.	
12. Support Member States in implementing operational research and surveillance activities to strengthen the capacity to use next generation sequencing in combination with phenotypic DST (ELI regional guidance).	

E. Equitable access to quality treatment and care for all people with TB, including those with DR-TB and TB comorbidities; and support for patients to facilitate treatment adherence

Treatment outcomes for TB are steadily improving but have not reached the regional target set for 2020, with treatment success rates of 75% for new and relapse TB registered in 2019, and success rates of 56% for MDR-TB and 51% for XDR-TB registered in 2018 (45). Clinical management and health system barriers are some of the factors causing these low treatment success rates in patients in DR-TB cohorts. Efforts should be intensified to ensure universal access to proven effective and safe treatment regimens for MDR/RR-TB and pre-XDR/XDR-TB both under programmatic and operational research conditions.

Ensuring equitable access to quality treatment and care for all people with TB everyone and to all communities, enshrining access to health care as a basic right through approaches that protect and promote equity, ethics, gender equality and human rights and through people-centred models of care in the Region will focus on: 1) integrated approaches to service delivery for TB and its comorbidities for all populations; 2) decentralizing treatment services; 3) empowering people and families affected by TB by giving them information and options; 4) prioritizing good clinical care and active drug-safety monitoring and management (aDSM); 5) ensuring treatment adherence using alternative modes of care delivery, including digital health technologies to the greatest possible extent; 6) integrating palliative and end-of-life care; and 7) providing post-TB care.

Treatment of DS-TB and DR-TB should follow the following key requirements for TB treatment regimens. Treatment should be: effective, by using drugs in combinations with possibility of shortening the duration of therapy; safe(r), by using medicines with proven safety profile; simple(r) drug administration, which is patient-friendly with no injectable agents and a lower pill burden; and affordable for national public health systems (46). Limited access to the new TB medicines in some Member States is often due to country-level barriers to the registration and importation of new medicines and a lack of mechanisms to address these barriers.

The rapid uptake of the latest WHO recommendations on DS-TB and DR-TB treatment with the fully oral treatment regimens will significantly contribute to a continued decrease in the disease burden in the Region in general, including in low-burden countries facing challenges with access to medicines for MDR/RR-TB. To that end, WHO will continue providing tailored country support to all countries by scaling up access to fully oral treatment regimens for DS-TB and MDR/RR-TB under programmatic and operational research conditions. Additionally, through its regional operational research initiatives, WHO will boost the uptake of the latest WHO recommendations, foster good clinical care, strengthen clinical and research capacity at the country level, introduce innovative programmatic approaches to care delivery and contribute to the generation of quality evidence for future recommendations.

From the health system perspective, by operationalizing the updated WHO recommendations on DS-TB and DR-TB treatment, including for TB in children and adolescents, in the regional context (46), the introduction of the fully oral regimens, with the potential shortening of treatment duration, should significantly optimize the programmatic costs associated with service delivery, introduce new models of care, and avoid the risks of nosocomial infection transmission, which will eventually lead to a decrease in the disease burden in the Region. WHO's aDSM framework needs to be applied to patients on any type of MDR/RR-TB regimen, to ensure appropriate action and an acceptable level of monitoring for, and prompt response to, adverse events – alongside monitoring for treatment responses and outcomes.

Increasing evidence has shown that the use of the new digital technologies as alternative treatment administration options, such as video-supported treatment (VST), can contribute to better treatment outcomes for TB and MDR/RR-TB (47), especially considering the trajectory towards use of the fully oral treatment regimens, and its use is important during health emergencies. Scaling up the use of digital adherence solutions for TB and the new people-centred models of care will contribute to an increase in treatment success and has indisputable advantages with respect to the reduction of stigma and discrimination associated with TB.

Currently, the implementation of VST in Member States is often limited to certain cohorts of patients and small-scale projects. Leveraging today's information and communication technologies for health can

help solve the challenges posed by conventional methods of TB care delivery for both professionals and affected communities and empower TB survivors and people affected by TB, which are all parts of the TB response. Through meaningful engagement of civil society and affected communities, WHO will continue improving the quality of, and access to, people-centred approaches to treatment of TB and MDR/RR-TB both at programmatic level and through the introduction of innovations and research.

Addressing TB, comorbidities and disability

Risk factors for comorbidities and disabilities among people with TB should be periodically assessed in collaboration with the relevant professional entities to prevent, treat and rehabilitate affected people, accordingly. Mechanisms for collaboration should be strengthened between NTPs and health programmes based on local epidemiology. Comorbidities and disabilities among people with TB should be addressed through the incorporation of comorbidity management and prevention, early detection and rehabilitation of TB-associated disability into the national TB guidelines and cross-referrals.

The dangerous mix of TB with (and alarming spread of) HIV, high levels of substance addiction, and high prevalence of viral hepatitis among people affected by TB, and especially MDR/RR-TB, are significant factors that continue to affect progress towards reaching the global targets of the End TB Strategy in the Region. Coordination between the national TB and HIV programmes is of particular importance to ensure quality treatment and care for PLHIV. Enhanced political and operational commitments to integrating HIV, TB and viral hepatitis services are needed to improve the health outcomes of patients with TB/HIV. HIV testing will be offered to all people with TB and PLHIV should be systematically screened for TB disease and evaluated for TPT (36,41).

Other common risk factors and comorbidities include diabetes mellitus and other noncommunicable diseases (NCD), undernourishment, mental health disorders, substance-use disorders (alcohol and illicit drugs) and tobacco use. In line with the EPW, Member States will be encouraged and supported to align their TB NSPs with national health strategies and other health programmes (HIV, sexually transmitted infections, maternal and child health, NCDs), and other related non-health areas, such as those dealing with penitentiaries, migration and poverty reduction. Specifically, to develop a regional framework to address mental health issues in people with TB, the Region will work closely with one of the EPW's flagship initiatives – the Pan-European Mental Health Coalition (9). The WHO European Framework for Action to Achieve the Highest Attainable Standard of Health for Persons with Disabilities 2022–2030 will pave the way for disability-inclusive health systems and the promotion of health and well-being of persons with disabilities of all ages, across contexts in the Region, including people with TB and DR-TB.

Priority actions for Member States

These priority actions are to be deployed by countries with respect to their health priorities, national legislation and context.

Priority actions	Timeline
1. Revise national policies and guidelines in line with the latest WHO recommendations on the treatment of TB and DR-TB for adults, children and adolescents.	Ongoing
2. Support the implementation of operational research initiatives for the introduction and use of novel treatment regimens for TB and DR-TB, including for comorbidities.	
3. Ensure the provision of good clinical care for TB, DR-TB and comorbidities, including the implementation of aDSM.	
4. Implement periodic assessments of risk factors and comorbidities associated with unfavourable treatment outcomes for DS-TB and DR-TB using routinely collected data.	Every 2 years starting 2025
5. Ensure the availability of options and infrastructure for the management of TB, DR-TB and comorbidities at outpatient settings.	By 2025
6. Ensure the provision of psychological and social support in a context-specific and individually sensitive manner, including through CSOs and communities.	By 2025

Priority actions	Timeline
7. Strengthen people-centred approaches for ensuring TB treatment adherence through digital adherence technologies (DATs), e.g. through the appropriate use of VST.	By 2025
8. Ensure the provision of palliative care services for people affected by TB.	By 2025
9. Improve approaches for screening of coinfections and comorbidities in TB, including viral hepatitis, alcohol-use disorders, undernutrition, mental health and disabilities, and ensure appropriate clinical management and support.	By 2025
10. Ensure access to counselling, psychological and social support for people affected by TB suffering from mental health and substance-use disorders.	By 2025

Priority actions for WHO and partner organizations

Priority actions	Timeline
1. Support countries in the update and alignment of national policies with WHO policies.	Ongoing
2. Provide tailored country support through regional mechanisms and platforms and regional operational research initiatives on the revision and development of national policies that are in alignment with the latest WHO recommendations on the treatment of TB and DR-TB for adults, children and adolescents.	Ongoing
3. Donors will support the introduction and scale-up of novel treatment modalities in line with the latest WHO guidance.	
4. Develop a generic operational research protocol for evaluating risk factors for unfavourable treatment outcomes and post-TB sequelae/morbidity at the country level.	By 2025
5. Support the further scale-up of digital adherence and treatment support technologies, including for patients with DR-TB and comorbidities.	Ongoing
6. Support the introduction and scale-up of people-centred approaches to ensure treatment adherence, including DAT, new models of care delivery and other alternatives to inpatient care.	By 2025
7. Support Member States with addressing palliative care through the use of available evidence, good practices and information exchange.	By 2025
8. Provide support on the initiation of studies on catastrophic expenditures.	By 2025
9. Provide strong advice to the Member States on models of care which liberate families and households from catastrophic expenses.	TBD
10. Provide, through technical units and mechanisms, tailored country support for the introduction of screening tools/methodologies for coinfections and comorbidities in TB, including viral hepatitis, substance-use disorders, undernutrition and mental health.	By 2025

Pillar 2: Bold policies and supportive systems

A. Governance and leadership

Political commitment is essential to accelerating responses to the TB epidemic that translate into the formulation of appropriate policies, allocation of resources, governance and accountability. The governance of a health system shapes its ability to produce equitable, sustainable, quality health care and, specifically, TB care and prevention services, leaving no one behind (48). The EPW stresses the importance of governance for improving both health and well-being, strengthening people-centred health systems and protecting people better against health emergencies (9). In addition, the TB epidemic is strongly influenced by social and economic development, health-related risk factors and geographical and financial access to health care. Therefore, addressing the broader determinants of the TB epidemic requires multisectoral action and accountability. Following the requests of Member States, expressed in the political declaration of the first WHO Global Ministerial Conference on Ending TB in the Sustainable Development Era in 2017, and in the political declaration of the UNHLM on TB in 2018 (5,6), WHO has developed and published a multisectoral accountability framework to accelerate the progress to End TB (MAF-TB) and to support Member States to implement it (XX). MAF-TB facilitates multisectoral action, mutual accountability and the measurement of progress towards TB commitments at global, regional, national and subnational levels.

In the European Region, MAF-TB implementation started in 2020 with baseline assessments in 18 Member States, including 10 high-burden TB countries. This included piloting the MAF-TB approach at the national level in Belarus, Kazakhstan, the Republic of Moldova, Tajikistan and Ukraine. As part of the piloting, the Regional Office supported countries to adapt the MAF-TB baseline assessment tools and to implement them. Baseline assessments are required to develop national MAF-TB roadmaps and establish or strengthen the national multisectoral coordination and review mechanisms needed to end TB. Community and civil society actors have key roles in this process through their engagement in community-driven and high-level advocacy, and in monitoring the TB response so that governments are accountable to the commitments they made in the political declaration of the UNHLM on TB in 2018.

Baseline assessments have shown that countries are at different stages of development of their MAF-TBs. Even though many countries have national coordination and review mechanisms for TB, mechanisms are still under health sector leadership which limits the engagement and accountability of the other relevant sectors and stakeholders that are involved, or that should be involved, in the TB response. The UN Secretary-General's 2020 report highlighted the importance of multisectoral engagement for progress towards ending TB and includes a request for WHO to continue supporting Member States to adapt and use MAF-TB and to lead periodic reviews of the TB response (49). WHO, together with other partners, will continue efforts to establish national MAF-TBs and build national capacities for its effective implementation. The results and lessons learned from the pilot projects will be expanded and used to support countries in MAF-TB-related processes.

As governments move towards UHC, national governance structures for TB need to align with broader health governance and to engage with a range of actors, including researchers and civil society actors, to ensure strategies, policies and services address all determinants and risk factors of TB, are accessible and meet all the needs of people with TB. Acknowledging that the burden and distribution of TB, as well as most common comorbidities, and other health-related risk factors that drive the TB epidemic) vary across countries, solutions to the integration of services, including at governance level, will need to be adapted to different epidemiological and health system contexts in line with the people-centred approach.

B. Health finance and universal health coverage

Achieving global targets for the reduction of the TB disease burden and improved access to TB prevention, diagnosis and treatment services requires progress towards UHC. Progress towards UHC is measured through a service coverage index (SCI) and the proportion of the population with large household expenditures on health as a share of total household expenditure. The European Region has registered progress in both indicators, as highlighted in the *Global tuberculosis report 2021* (10). The End

TB Strategy includes a target of zero catastrophic costs (including direct medical expenditures, nonmedical expenditures and income losses) because of TB disease. To date, few countries in the Region have conducted TB cost surveys; however, the existing evidence on financial barriers shows that most expenditures incurred by patients are not medical. Actions should be taken to address nonmedical expenditures and income losses, as well as social protection.

Progress in reducing the burden of TB disease requires adequate funding sustained over many years. In the Region, most of the funding available comes from domestic sources. The availability of full funding for an efficient TB response remains a challenge. During 2010 to 2020, the gaps between the funding required by TB NSPs and the available funding has significantly reduced; however, in 2020 these gaps increased as a result of the impact of COVID-19 on sustaining funding levels for TB. Efficient funding allocation and provider payment mechanisms are fundamental to developing health and social services that will support the TB targets. Appropriate coverage of TB interventions in basic packages is needed to support the fulfilment of UHC principles for TB prevention and care.

In the central and eastern part of the Region, financial arrangements have historically been designed around the delivery of services predominantly in hospital settings and have been slow to reorient provider incentives to manage patients in ambulatory and community settings. Transformation from input-based budgeting to strategic purchasing allows the alignment of payment methods to the configuration of the service-delivery model and stimulates providers to improve early diagnosis, access and adherence to treatment, strengthens patient support and decreases unnecessary hospital admissions and excessive lengths of stay. During 2016 to 2020, this transition has been initiated in a number of TB high-priority countries. The circumstances surrounding the COVID-19 pandemic have accelerated the transition towards decentralized care in communities and the use of DATs, calling for the need to further adjust payment methods to cover service-delivery adaptations and digital health. As many of the EECA countries are on a pathway of transitioning away from donor funding, timely financial allocation and sustainable financing for key services and health products such as TB diagnostics and medicines require realignment of government resources to match strategic imperatives.

C. Health workforce including community health workers

The health workforce is vital in every health system. Placing the person at the centre of the model of care requires a broad range of services to be deployed by a range of health and non-health professionals, including psychologists, social workers, peers and community workers. With the shift to more decentralized models of primary care, it is vital that TB services include roles for community-based service providers to ensure that people are retained in care and receive services in an equitable manner. However, many countries grapple with major health workforce challenges, such as critical shortages in the supply of workers, an inadequate mix of skills in the workforce, inequitable geographical distributions of health workers, and gaps in their competencies, motivation and performance (51).

As the disease burden decreases, and to attract young doctors, merging TB specialties with lung or infectious disease specialties has been a key strategy; however, uptake has been slow in some Member States. Human resource strategic planning is needed to strike a balance between a reduced TB specialist workforce, the gradual shifting of the tasks performed by these specialists to other health care services, and the need to sustain the core functions of TB programmes. These changes also need to consider shifts in medical education, including the future of single disease specialties, and the option of merging with other specialties, such as pulmonology or infectious disease (51).

The COVID-19 pandemic has demonstrated the importance of health and care workers to the health system, and has highlighted the need to invest in the health labour market and to achieve a better understanding of the forces that drive health worker shortages and surpluses, the available skills mix and geographical skills imbalances, suboptimal performances, and to develop effective policies to address these issues, which is at the core of the *Global strategy on human resources for health: workforce 2030* (52). the gradual shifting of the tasks performed by these specialists to other health care services,

D. Strategic information and digital health

Surveillance and response monitoring

Information generated through the systematic collection, analysis and dissemination of epidemiological surveillance and routine programmatic data is vital to informing policy, planning and well-targeted interventions. Despite substantial investment and progress in the Region, many countries continue to face multiple challenges related to data systems, including poor data quality, siloed and fragmented data systems, heavy reporting burdens for front-line workers, and limited capacity for analysis and use of data at the local, national and subnational levels. Fragmented data management systems used by disease programmes are often disconnected from comprehensive national health information systems and operate in isolation.

The vast majority of countries in the WHO European Region capture data for notified TB cases in digital case-based surveillance systems, allowing for more timely access to data and availability of individual patient data at the level of health facilities and up to the national level. By including disaggregation by age, sex, location and key programme indicators in their data systems, many countries facilitate data analysis to provide information that allow adaptation and targeting of response efforts, both geographically and for specific population groups, nationally and at the subnational level. WHO will continue to promote digital TB case surveillance, and will support real-time digital data collection in the Region.

It is also important to have mechanisms to gather quantitative and qualitative data and observations from service users and communities to assess the availability, accessibility, acceptability, equity and quality of services they receive. WHO will support community-led monitoring and its appropriate integration into the TB and HIV information systems.

Digital health

Digital health solutions have the potential to convert conventional service-delivery modalities into more accessible and convenient solutions, which have greater levels of effectiveness and efficiency. With the introduction of decentralized testing platforms requiring connectivity to electronic tools for monitoring operations and facilitating of results, all-oral shorter and longer treatment regimens for DR-TB that enable the use of digital adherence technologies (DAT), and given the challenges brought by health emergencies, scaling up digital health solutions is the new reality (46).

Community-led monitoring through digital tools empowers and engages people affected by TB to know their rights and to report the barriers that prevent them from being diagnosed, treated and cared for. This information is then used by communities and national TB programmes to address these gaps and challenges and to reach those who have been left behind. Empowerment through Digital Health is one of the four flagship initiatives of the EPW, which supports the GPW 13 (9), and sets out a vision highlighted in the *Regional Digital Health Action Plan for the WHO European Region 2023–2030*. The Regional Office will support countries in leveraging and scaling up digital transformations for better health and aligning digital technology investments in decision-making with their health system needs, while fully respecting the values of equity, solidarity and human rights.

E. Procurement and supply-chain management

Central to the uptake of the new technologies, such as the new diagnostic tools and treatment regimens, is the capacities of governments to ensure access to these technologies and also to ensure their affordability. In the context of the COVID-19 pandemic, countries are under pressure to maintain the delivery of essential health products, including priority diagnostics and medicines for TB, and emergency medicines and health products (53).

Procurement and supply management (PSM) systems for medicines and health products are complex. These systems must meet the health needs of populations, while ensuring regulatory coherence, providing value for money and offering supply continuity. Furthermore, PSM systems require close coordination with multiple partners.

Priority actions for Member States

These priority actions are to be deployed by countries with respect to their health priorities, national legislation and context.

Priority actions	Timeline
1. Ensure whole-of-government and whole-of-society approaches to end TB through multisectoral, multistakeholder and inclusive collaborations and partnerships, including civil society and affected communities, that are accountable and transparent.	Ongoing
2. Ensure the adaptation and use of MAF-TB at the national level including conducting the MAF-TB baseline assessment, development of the National Multisectoral Coordination and Accountability Framework and establishing multisectoral coordination and review mechanisms.	By 2025
3. Ensure the development of comprehensive and costed national TB policies, strategies and budgeted plans, developed in line with latest WHO policy guidance on TB and DR-TB, and the UHC framework.	By 2025
4. Adjust plans for the integration of health services to better fit the needs of people with comorbidities and key and vulnerable populations based on the findings of external and internal reviews and other assessments.	By 2025
5. Mobilize resources for health and the drive towards UHC to provide adequate financing of TB services at all levels. Scale-up domestic resources to ensure the availability of the full funding needed to get back on track after the COVID-19-related disruption.	Ongoing
6. Expand the financial access of services to all people, especially vulnerable groups and key populations, irrespective of their ability to pay to alleviate out-of-pocket costs and reduce catastrophic costs.	Ongoing
7. Align the strategic purchasing of TB services with a stronger role of primary care, including community care, through the adoption and scale-up of TB clinical and supportive service packages. Enhance public financing of supportive TB services provided by civil society and community-led organizations.	Ongoing
8. Increase the availability of data for domestic investments into TB to inform analysis and take actions to improve the allocative efficiency of national TB domestic expenditure.	Ongoing
9. Ensure task shifting across the health workforce to provide the right number and mix of health and non-health workers.	Ongoing
10. Provide continuing professional development to the health workforce consistent with national guidelines developed based on the latest WHO policy guidance on TB prevention, screening, diagnosis, treatment and care.	Ongoing
11. Transform medical education to merge the TB specialty with the pulmonology/infectious disease specialty in pre-service and graduate institutions to allow a strategic shift from a narrow disease-minded education to a broader integrated people-oriented education.	Ongoing
12. Provide adequate regulation, capacity-building and support for community-based members of the health workforce.	Ongoing
13. Ensure the functioning of case-based data systems for real-time data recording, reporting and use for programmatic management and research purposes.	Ongoing
14. Scale-up the use of digital health technologies throughout the TB care pathway.	Ongoing
15. Strengthen in-country regulatory processes, procurement capacity and mechanisms, supply chains, and management information systems to ensure access and availability of high-quality and affordable TB tests, diagnostics and medicines and related supplies.	Ongoing
16. Optimize the registration process to enable a more rapid uptake of new technologies, novel drugs and diagnostics.	Ongoing

Priority actions	Timeline
17. Improve the affordability of new products by expanding price decreasing strategies and agile procurement mechanisms.	Ongoing
18. Develop and implement TB recovery plans for preparedness, essential service operations and recovery in the context of health and humanitarian emergencies phases.	By 2023

Priority actions for WHO and partner organizations

Priority actions	Timeline
1. Support countries to adapt, implement and report on the MAF-TB across all its key elements, including the evaluation of the baseline situation on the multisectoral TB response, defining political commitments and targets in line with global and regional commitments, the establishment or formalization of multisectoral coordination and review mechanisms, addressing multisectoral actions on the TB response; and strengthening systems for monitoring and reporting, and review mechanisms.	By 2025
2. Support countries to further use WHO's people-centred framework for TB care planning and budgeting, and the recommended tools for evidence-based decisions, integrated with the overall national processes and cycles of national health planning.	Ongoing
3. Support Member States in revising or developing their TB NSPs with their National Health Strategies and other programmes (such as HIV, mother and child health, NCD programmes) and other related non-health sector strategies (such as those for prisons, migration and education) using standardized approaches and tools.	By 2025
4. Provide technical guidance and policy options through various regional platforms and mechanism (i.e. the European Laboratory Initiative (ELI), the European TB Research Initiative (ERI), the regional Green Light Committee (rGLC) and the RCC-THV) to improve the performance and efficiency of NTPs.	By 2025
5. Support policy options for the integration of TB and other communicable diseases depending on the country epidemic and health system context within the framework of the UN Common Position on Ending HIV, TB and Viral Hepatitis through Intersectoral Collaboration.	By 2025
6. In partnership with the Global Fund to Fight AIDS, Tuberculosis and Malaria, and through cross-divisional work, the Secretariat will continue guiding eligible Member States through tailored in-country technical support on sustainable financing for TB prevention and care, supporting health and financing reforms and shifting towards outpatient models of care with sustainable financing and well-aligned payment mechanisms.	Ongoing
7. Estimate resource needs to achieve the targets at the regional level and strengthen partnerships to mobilize the resources needed to get back on track and achieve targets.	By 2023
8. In partnership with the geographically dispersed office (GDO) on Primary Care in Almaty, provide eligible Member States technical support for the inclusion and costing of essential components of TB prevention and care to be delivered at the PHC level.	Ongoing
9. Improve resource tracking to monitor expenditure trends in hospitals, and outpatient and community settings.	Ongoing
10. Provide support to operationalize a health labour market framework to analyse the health workforce needed to implement quality TB services and facilitate the development of the appropriate policy recommendations.	Ongoing
11. Provide support to develop and maintain case-based data systems for real-time data recording and reporting. Capitalize on the COVID-19 experience and strengthen digital TB surveillance and monitoring for timely responses.	Ongoing

Priority actions	Timeline
12. Support the strengthening of the capacity to collect, analyse and use the robust surveillance and programme monitoring data from Member States to ensure that recording and reporting of TB data at the country level meets WHO's definitions, and that the assessments of progress towards global and regional targets and milestones are as rigorous and robust as possible.	Ongoing
13. Jointly with the ECDC, continue to coordinate TB surveillance and monitoring in the Region, ensuring data standardization and quality across countries.	Ongoing
14. Support the scale-up for the use of digital health technologies throughout the TB care pathway.	Ongoing
15. In partnership with the Stop TB Partnership's Global Drug Facility and the rGLC, and through cross-divisional work, support government takeover of the procurement of TB drugs and supplies in high-burden countries, using international channels for procurement and ensuring proper maintenance and servicing for novel diagnostics. Coordinate these efforts across programmes, agencies and donors.	Ongoing
16. Improve access, affordability and accessibility of medicines, diagnostics, vaccines and other health products, through enhanced policy dialogue, advocacy, expanding voluntary intercountry collaborative platforms and supranational procurement groups.	Ongoing

Pillar 3: Intensified research and innovation

To reach the End TB Strategy targets, substantial interventions and the rapid introduction of innovations are necessary (1). This will require the introduction and use of operational research³ to design, implement and scale-up innovations, and will also require an urgent increase in financial investment in research and innovations to allow the development of new tools with the potential to be made rapidly available and widely accessible in the next decade. Further research is desperately needed to put a stop to the suffering inflicted by TB, DR-TB and their comorbidities.

In the Region, the high prevalence of MDR/RR-TB, comorbidities and coinfections yet poses a significant threat to the progress towards the global targets of the End TB Strategy. As the demands on health services continue to grow, many health programmes are operating under challenging conditions and financial constraints. Over the past decade, efforts have been made to increase the MDR/RR-TB treatment success rates, with mainly positive trends being observed since the recommendations of the new medications for MDR-TB treatment. No point-of-care testing is currently available for TB and the effectiveness of treatment regimens needs to be increased, with full access to new medicines ensured across the Region. At-risk groups, such as migrants and people deprived of liberty, are neglected priorities, and little is known about the best response strategies for these populations. Finally, the End TB Strategy 2030 targets will be missed without a breakthrough in new and effective vaccines protecting against TB (54).

In line with the strategic objectives of the new *Global Strategy for Tuberculosis Research and Innovation* (55), the Regional Office remains committed to accelerating TB research and innovation and improving equitable access to the benefits of research to help the Region move towards TB elimination through the following two implementation areas:

- the discovery, development and rapid uptake of new tools, interventions and strategies; and
- the research to optimize implementation and impact, and promote innovation.

The European Tuberculosis Research Initiative (ERI-TB), launched in 2017, serves as a platform for the continued and expanded collaboration of multiple partners, including the network of WHO collaborating

³Implementation research is the scientific study of methods to promote the systematic uptake of research findings and other evidence-based practices into routine practice, and, hence, to improve the quality and effectiveness of health services and care (57).

centres and academia, for research and innovation in the Region (56). A partnership with the Special Programme for Research and Training in Tropical Diseases (TDR) and the involvement of civil society to implement research addressing the behavioural and social determinants of TB ensures complementary collaboration and excludes duplication of efforts.

At the regional level, the network enables the rapid implementation of strategic initiatives, advocates for enhanced TB research funding, and supports intercountry research uptake by engaging and bringing together NTP managers, researchers and civil society representatives. Globally, ERI-TB serves as a model to establish regional TB research networks and facilitate the uptake and scale-up of research (54).

The regional TB research agenda is linked to the priorities of WHO's *Global Strategy for Tuberculosis Research and Innovation* and aims to support efforts by governments and other partners to accelerate TB research and innovation, and to improve equitable access to the benefits of research (55). Regular revision of Region-specific priority research questions for the prevention, diagnosis, treatment and care for TB and coinfections are based on the dynamic operational context, disease burden, new evidence and countries' needs. These Region-specific priority research questions require collaboration between national TB and HIV programmes and non-state actors to help to translate them into effective and appropriate actions at the national level. Additionally, the UN Common Position on Ending HIV, TB and Viral Hepatitis Through Intersectoral Collaboration has identified research as a shared principle for addressing all three diseases (29).

Operational research, as a mechanism close to programmatic implementation, has been supported by WHO to boost the uptake of the latest WHO recommendations on TB prevention, diagnosis, treatment and care. For example, several regional operational research initiatives have already been supporting the transition to fully oral treatment regimens that has led to improvements of good clinical care through the optimization of clinical monitoring, the introduction of effective diagnostic algorithms, and strengthened national research capacity, and which has also generated quality evidence for new WHO recommendations. In addition, operational research provides decision-makers with information to enable them to improve the performance of their health programmes.

Hence, the progress towards regional targets depends hugely on the commitment to end TB, the agility of national legislative mechanisms and the increased financial investment to support the introduction and uptake of research and novel approaches on TB prevention, diagnosis, treatment and care.

Priority actions for Member States

These priority actions are to be deployed by countries with respect to their health priorities, national legislation and context.

Priority actions	Timeline
1. Revise the legislative mechanisms and prepare the infrastructure for the implementation of preclinical, clinical, operational and health system research and the rapid uptake of innovations.	By 2025
2. Ensure the allocation of resources for the implementation of research, and the introduction and uptake of innovations that are in line with the latest WHO guidance.	Ongoing
3. Develop national TB research plans with budget estimations and resource mapping reflected in the revised NSPs.	By 2025
4. Establish TB research units at the national level with mandates to define, coordinate and monitor the implementation of national TB research agendas and to develop the national research ethics review network.	By 2025
5. Ensure the use of programmatically collected data for operational, implementation and health system research purposes.	Ongoing
6. Promote collaboration between young researchers and NTPs to advance national and regional TB research priorities.	Ongoing
7. Support collaboration between NTPs and universities to offer courses on TB research as a part of training curricula for public health professionals.	Ongoing

Priority actions	Timeline
8. Create enabling environments for the postgraduate education of TB researchers and international exchange.	By 2027

Priority actions for WHO and partner organizations

Priority actions	Timeline
1. Lead the implementation and country support of the ongoing and new regional operational research initiatives.	Ongoing
2. Where applicable, develop new research initiatives to support the uptake of the latest WHO policy guidance and generate new quality evidence for future recommendations.	Ongoing
3. Based on the evidence, advocate for domestic and donor budget allocation for rapid uptake of innovations and research. Domestic budget allocation will require Member States to review/update current legislation, regulating the implementation of research activities.	Ongoing
4. Collect and share best practice on the rapid uptake of innovations by Member States.	Ongoing
5. Support Member States to address the issues of ethics in research to ensure that everyone, including key, vulnerable and underserved populations, benefits from up-to-date findings from scientific research.	
6. Revise priority research questions and update the European TB research agenda in consultation with Member States.	By 2023
7. Support Member States in designing and updating the national TB research agendas reflected in the revised TB NSPs.	Ongoing
8. Support Member States with the implementation of ongoing and new regional operational research initiatives focused on improving treatment success for TB, DR-TB and comorbidities, TPT for contacts of DR-TB, service delivery and others, depending on the priorities of national TB research agendas.	Ongoing
9. Establish a network of research ethics review bodies to ensure compliance with the internationally accepted standards required for research.	By 2027
10. Promote, through ERI-TB and the network of WHO collaborating centres, information and experience exchanges between research professionals on a regular basis.	Ongoing
11. Establish a network for collaboration and exchange between young researchers as part of ERI-TB.	By 2027

Partnerships, accountability and progress monitoring

Partnerships

Implementing the Regional Action Plan, as well as sustaining previous gains and making advances in implementation, can only be accomplished by the countries in the Region through effective partnerships.

At the core of any country response should be a three-way collaboration of: (1) health systems that include both national programmes and multisectoral engagement; (2) CSOs and their knowledge of and experience with key populations and those most at risk; and (3) disease-specific technical expertise, which can be offered by WHO and partner agencies, including national and regional research agencies and universities.

Accountability, monitoring and reporting

Member States should develop or update their NSPs in alignment with the new targets and milestones in the TB Action Plan. National goals and targets should consider, and be responsive to the country

context, including the nature and dynamics of epidemics, the populations affected, the structure and capacity of health care and community systems, national regulations and resource mobilization.

Driving continued progress towards ending TB will require regular and transparent monitoring, and accountability frameworks and reporting mechanisms. This will enable periodic monitoring and reviewing of priorities and realigning of resources. Regular updates on the progress that has been made towards implementing the TB Action Plan will be presented and reviewed at annual meetings of the Region's NTP managers and national TB focal points. The monitoring framework is presented in detail in Annex 1.

WHO will report on the progress made in implementing the TB Action Plan to the WHO Regional Committee for Europe in 2026 in an interim report charting the progress made and the challenges identified up to 2025. In 2031, the final report of the TB Action Plan, detailing the overall progress in the Region by 2030, will be submitted.

References

1. WHO. Global strategy and targets for tuberculosis prevention, care and control after 2015. Resolution WHA67.1. Geneva: Sixty-seventh World Health Assembly; 19–24 May 2014.
2. United Nations. Transforming our world: the 2030 Agenda for Sustainable Development. Resolution A/RES/70/1. New York: United Nations; 2015.
3. United Nations. SDG 3. Ensure healthy lives and promote well-being for all at all ages. New York: United Nations Department of Economic and Social Affairs; 2020 (<https://sdgs.un.org/goals/goal3>, accessed 6 July 2022).
4. Tuberculosis action plan for the WHO European Region 2016–2020. EUR/RC65/17 Rev.1. Regional Committee for Europe, 65th session. Copenhagen: WHO Regional Office for Europe; 2015 (https://www.euro.who.int/__data/assets/pdf_file/0007/283804/65wd17e_Rev1_TBActionPlan_150588_withCover.pdf, accessed 6 July 2022).
5. First WHO Global Ministerial Conference. Ending TB in the sustainable development era: a multisectoral response. Geneva: World Health Organization; 2017 (<https://apps.who.int/iris/bitstream/handle/10665/345527/WHO-HTM-TB-2017.11-eng.pdf?sequence=1&isAllowed=y>, accessed 6 July 2022).
6. United Nations. Political declaration of the high-level meeting of the General Assembly on the fight against tuberculosis. Resolution A/RES/73/3. New York: United Nations; 2018.
7. Summary of the final report on implementation of the Tuberculosis Action Plan for the WHO European Region 2016–2020. EUR/RC70/8(N). Regional Committee for Europe, 70th session, Virtual session; 14–15 September 2020.
8. Technical Advisory Group on Tuberculosis for the WHO European Region: report of the Fifteenth Meeting 18–20 May 2021. Virtual meeting hosted out of Copenhagen, Denmark. Copenhagen: WHO Regional Office for Europe; 2021.
9. European Programme of Work 2020-2025: United Action for Better Health. Copenhagen: WHO Regional Office for Europe; 2021.
10. Global tuberculosis report 2021. Geneva: World Health Organization; 2021.
11. ECDC. Tuberculosis surveillance and monitoring in Europe 2022–2020 data. Copenhagen and Stockholm: WHO Regional Office for Europe and European Centre for Disease Prevention and Control; 2022 (<https://www.ecdc.europa.eu/en/publications-data/tuberculosis-surveillance-and-monitoring-europe-2022-2020-data>, accessed 16 June 2022).
12. Final report on implementation of the Tuberculosis Action Plan for the WHO European Region 2016–2020. Copenhagen: WHO Regional Office for Europe; 2020.
13. Glaziou P. Predicted impact of the COVID-19 pandemic on global tuberculosis deaths in 2020. medRxiv2020042820079582.20079582.
14. Madhukar P., Kasaeva T. Swaminathan S. COVID-19's devastating effect on tuberculosis care – a path to recovery. N Engl J Med 2022; 386:1490-1493.
15. ECDC. Tuberculosis surveillance and monitoring in Europe, 2021–2019 data. Stockholm: WHO Regional Office for Europe and European Centre for Disease Prevention and Control; 2021.
16. Stop TB Partnership. Declaration of the rights of people affected by tuberculosis. Geneva: Stop TB Partnership; 2019 (<https://stoptb.org/assets/documents/communities/FINAL%20Declaration%20on%20the%20Right%20of%20People%20Affected%20by%20TB%2013.05.2019.pdf>, accessed 16 June 2022).
17. Stop TB Partnership. A deadly divide: TB commitments vs. TB realities. A communities report on progress towards the UN political declaration on the fight against TB and a call to action to close the gaps in TB targets. Geneva: Stop TB Partnership; 2020.
18. Dara M KG, Yedilbayev A, et al. Early COVID-19 pandemic's toll on tuberculosis services, WHO European Region, January to June 2020 [published correction appears in Euro Surveill. 2021 Jul;26(26)]. Euro Surveill.26(24):2100231.
19. A people-centred model of tuberculosis care. A blueprint for eastern European and central Asian countries. Copenhagen: WHO Regional Office for Europe; 2017.

20. WHO Information Note: tuberculosis and COVID-19. Geneva: World Health Organization; 2020.
21. WHO Information Note: COVID-19 considerations for tuberculosis (TB) care. Geneva: World Health Organization; 2021 (www.who.int/publications/i/item/WHO-2019-nCoV-TB-care-2021.1, accessed 16 June 2022).
22. Building health systems resilience for universal health coverage and health security during the COVID-19 pandemic and beyond: WHO position paper. Geneva: World Health Organization; 2021 (<https://www.who.int/publications/i/item/WHO-UHL-PHC-SP-2021.01>, accessed 16 June 2022).
23. Realizing the potential of primary health care: lessons learned from the COVID-19 pandemic and implications for future directions in the WHO European Region (EUR/RC71/R3). Virtual session: Regional Committee for Europe, 71st session; 13–15 September 2021.
24. The End TB Strategy: Global strategy and targets for tuberculosis prevention, care and control after 2015. Geneva: World Health Organization; 2014.
25. European Observatory on Health Systems and Policies, Winter R, Perehinets I, Dara M, van den Boom M et al. People-centred TB prevention and care in eastern Europe and central Asia. *Eurohealth*. 2018;24(4):13–17.
26. WHO. Tracking universal health coverage: 2017 global monitoring report. Geneva: World Health Organization and International Bank for Reconstruction and Development/The World Bank; 2017 (<https://apps.who.int/iris/bitstream/handle/10665/259817/9789241513555-eng.pdf>, accessed 16 June 2022).
27. Tuberculosis Regional Eastern European and Central Asian Project (TB-REP). Copenhagen: WHO Regional Office for Europe (<https://www.euro.who.int/en/health-topics/communicable-diseases/tuberculosis/areas-of-work/community-engagement-and-advocacy/tuberculosis-regional-eastern-european-and-central-asian-project-tb-rep>, accessed 5 November 2021).
28. Tuberculosis Regional Eastern European and Central Asian Project (TB-REP) 2.0. Copenhagen: WHO Regional Office for Europe ([https://www.who.int/europe/initiatives/tuberculosis-regional-eastern-european-and-central-asian-project-\(tb-rep\)](https://www.who.int/europe/initiatives/tuberculosis-regional-eastern-european-and-central-asian-project-(tb-rep)), accessed 6 July 2022).
29. United Nations. United Nations Common Position on Ending HIV, TB and Viral Hepatitis through Intersectoral Collaboration. Copenhagen: WHO Regional Office for Europe; 2018.
30. Piloting United Nations Common Position on Ending HIV, TB and Viral Hepatitis in Georgia: a mission report to Georgia, 5–11 May 2019. Copenhagen: WHO Regional Office for Europe; 2019 (<https://apps.who.int/iris/handle/10665/345957>, accessed 16 June 2022).
31. Standardized package of community-based support services to improve TB outcomes. Copenhagen: WHO Regional Office for Europe; 2021.
32. Nazareth J, Baggaley RF, Divall P, Pan D, Martin CA et al. What is the evidence on existing national policies and guidelines for delivering effective tuberculosis, HIV and viral hepatitis services for refugees and migrants among Member States of the WHO European Region? Copenhagen: WHO Regional Office for Europe; 2022 (<https://apps.who.int/iris/handle/10665/352055>, accessed 6 July 2022).
33. Constitution of the World Health Organization. Geneva: World Health Organization; 1948.
34. Western Pacific Regional Framework to End TB (2021–2030). Himeji: WHO Regional Committee for the Western Pacific, 72nd session; 25–29 October 2021.
35. Centre for Health Policies and Studies. Breaking the Silence: Human Rights, Gender, Stigma and Discrimination Barriers to TB Services in Georgia, Kazakhstan, Kyrgyzstan, Tajikistan and Ukraine. Chisinau: Centre for Health Policies and Studies; 2020 (<http://pas.md/en/PAS/Studies/Details/214>, accessed 16 June 2022).
36. WHO consolidated guidelines on tuberculosis. Module 1: prevention – tuberculosis preventive treatment. Geneva: World Health Organization; 2020.
37. Tuberculosis elimination in the WHO European Region: review of key actions, with a special focus on tuberculosis infection management. Copenhagen: WHO Regional Office for Europe; 2020.
38. WHO Civil Society Task Force On TB; U.S. Centers for Disease Control and Prevention. Call to Action 2.0: A global drive to scale up TB prevention. Geneva: World Health Organization; 2021 (https://cdn.who.int/media/docs/default-source/hq-tuberculosis/call-to-action-2.0-a-global-drive-to-scale-up-tb-prevention.pdf?sfvrsn=6f938b38_7&download=true, accessed 16 June 2022).

39. WHO Guidelines on tuberculosis infection prevention and control, 2019 update (WHO/CDS/TB/2019.1). Geneva: World Health Organization; 2019.
40. BCG vaccine: WHO position paper, February 2018 – Recommendations. *Vaccine*. 2018;36:3408–10.
41. WHO consolidated guidelines on tuberculosis Module 2: Screening – Systematic screening for tuberculosis disease. Geneva: World Health Organization; 2021.
42. WHO operational handbook on tuberculosis. Module 2: screening – systematic screening for tuberculosis disease. Geneva: World Health Organization; 2021.
43. National guidelines on systematic screening for tuberculosis disease and tuberculosis preventive treatment. Kazakhstan. Almaty: National TB and Lung Disease Research Centre, WHO Regional Office for Europe; 2021 [in press].
44. WHO consolidated guidelines on tuberculosis. Module 3: Diagnosis – rapid diagnostics for tuberculosis detection 2021 update. Geneva: World Health Organization; 2021.
45. Tuberculosis profile. Copenhagen: WHO Regional Office for Europe ([https://worldhealthorg.shinyapps.io/tb_profiles/?_inputs_&lan="EN"&entity_type="group"&group_code="EUR"](https://worldhealthorg.shinyapps.io/tb_profiles/?_inputs_&lan=), accessed 5 November 2021).
46. WHO consolidated guidelines on tuberculosis. Module 4: treatment – drug-resistant treatment. Geneva: World Health Organization; 2020.
47. Quick guide to video-supported treatment of tuberculosis. Copenhagen: WHO Regional Office for Europe; 2020.
48. European Observatory on Health Systems and Policies. Strengthening Health System Governance. Better policies, stronger performance. Copenhagen: WHO Regional Office for Europe; 2016.
49. Multisectoral accountability framework to accelerate progress to end tuberculosis by 2030. Geneva: World Health Organization; 2019.
50. United Nations. Progress towards the achievement of global tuberculosis targets and implementation of the political declaration of the high-level meeting of the General Assembly on the fight against tuberculosis. Report of the Secretary-General (A/75/236). New York: United Nations; 2020.
51. Health labour market analysis guidebook. Geneva: World Health Organization; 2021.
52. Global strategy on human resources for health: workforce 2030. Geneva: World Health Organization; 2016.
53. Strategic procurement and supply. Copenhagen: WHO Regional Office for Europe (<https://www.euro.who.int/en/health-topics/Health-systems/health-technologies-and-medicines/policy-areas/strategic-procurement-and-supply>, accessed 5 November 2021).
54. Dara M, Dadu A, Korotych O, Yedilbayev A. Scaling up tuberculosis research in the WHO European Region. *Public Health Panorama*. 2019; 5:378–82.
55. Global strategy for tuberculosis research and innovation. Geneva: World Health Organization; 2020 (
56. Defining the tuberculosis research agenda for the WHO European Region: a study report of the European TB Research Initiative. Copenhagen: WHO Regional Office for Europe; 2019.
57. Eccles MP, Mittman BS. Welcome to implementation science. *Implement Sci*. 2006;1:1.
58. Plan to Stop TB in 18 High-priority Countries in the WHO European Region, 2007–2015. Copenhagen: WHO Regional Office for Europe (<https://apps.who.int/iris/handle/10665/345352>, accessed 6 July 2022).
59. Vesga JF, Arinaminpathy N. Modelling tuberculosis control priorities: more of the same will not do – Authors' reply. *Lancet Glob Health*. 2019;7:e1320. doi: 10.1016/s2214-109x(19)30283-9.

Annexes

Annex 1 Monitoring and evaluation framework

The Tuberculosis Action Plan for the WHO European Region 2023–2030 is supported by a monitoring framework that enables a harmonized approach to monitor both the progress towards the 2025–2030 targets at both the national and regional levels and the actions taken to put the End TB Strategy into practice. Monitoring is not limited to tracking data on TB surveillance and implementation of activities, but also includes evaluating the effectiveness and impact of interventions, consequently providing the foundation for advocacy and policy development.

The current document follows the structure of the previous monitoring framework of the WHO European Region TB Action Plan 2016–2020, with the overall intention of keeping the limited number of indicators and maintaining the details on the calculations of each of the indicators used. Limiting the number of indicators is intended to avoid overcomplicating the framework, to focus on the issues that directly affect decision-making and to provide measures of effectiveness.

The framework consists of 30 indicators that allow monitoring of the performance of the areas of interventions in the TB Action Plan. Ten indicators were selected as the core indicators for monitoring and reporting to the WHO Regional Committee for Europe (these indicators are marked (E) in Table A1.1). The list of indicators closely follows the structure of the TB Action Plan. Almost every area of intervention is reflected in the framework by one or more indicators, to represent the most accurate measure of performance of the group of activities.

The monitoring and evaluation framework includes indicators that allow oversight of the progress made towards the achievement of the regional targets, and includes:

- impact indicators to measure progress towards the three End TB Strategy and WHO European Region targets;
- outcome indicators to monitor broader changes in TB control, which will be enhanced as a result of implementing the set of interventions recommended in the TB Action Plan;
- output indicators to monitor progress of specific interventions measuring policy environment, commitment and capacity among Member States.

Indicator development was guided by principles which defined that the indicators should be:

- sufficiently broad to reflect all aspects of the ambitious Action Plan;
- specific enough to address critical markers of success; and
- concise, so as not to overburden national programmes.

In addition, the selection of indicators was harmonized with the End TB Strategy's recommended top 10 global indicators, highlighted in the list with G (Global), and focused on indicators that are collected regularly through routine recording and reporting. These indicators, while regional in scope, are designed to serve as a guide to the development or adjustment of comprehensive monitoring plans at country level.

For each indicator/group of indicators, baseline value, desired target, assessment frequency, data source, layers of analysis and monitoring mechanism are defined. The framework includes quantitative and qualitative indicators: for quantitative indicators, numerators and denominators are listed; for qualitative, the basic criteria of favourable assessment (Yes/No) are listed.

Baseline levels, in most cases, were defined using information provided by each country through the WHO/ECDC annual TB data collection process. This is standardized to the WHO-recommended recording and reporting framework, has Region-wide coverage, is undertaken only once per year (therefore avoiding duplication of effort by countries and partners) and ensures a user-friendly mechanism for data collection. The absence of baseline information in a limited number of indicators from the full list might be explained by the unavailability of these data and/or questionable reliability of the information available.

To prioritize the area of intervention, indicators will be measured according to the following layers: high-priority countries for ending TB in the WHO European Region;⁴ European Union/European Economic Area countries; and WHO European Region countries. Analysis by country will be performed to assess country-specific benchmarks, performance over time and the eventual achievement of all objectives.

Most indicators will be monitored annually. In addition to the joint WHO/ECDC annual data collection, desk reviews will be performed at the beginning of the Action Plan implementation, and when full implementation is expected, to monitor activities that are not reflected in the WHO/ECDC TB data collection form. In-depth assessment of reports from countries and external technical support will provide additional material to support the measurement of indicators. In the absence of these main sources of information, an interview with the national programme (or equivalent) will be undertaken to assess performance on interventions implemented as part of the Action Plan. Only data approved by Member States will be used to monitor the Action Plan.

The indicators outlined in the regional monitoring framework should be integrated with national TB control programme monitoring and evaluation (M&E) frameworks at the country level. In addition to the indicators outlined in the regional framework, countries may also include additional indicators to monitor progress of national strategies, taking into account country-specific priorities.

The full results of assessments of performance on interventions delivered through the implementation of the Action Plan will be presented biennially via a joint WHO/ECDC report on TB surveillance and monitoring in Europe. The report will consist of analysis and interpretation of data based on the indicators and will include recommendations. The progress in the implementation of the TB Action Plan will be reported every 2 years to the Regional Committee and monitoring reports will be presented to the meeting of national TB programme managers/country focal points that is open to stakeholders and CSOs involved in TB control in the Region.

⁴High-priority countries for TB control in the WHO European Region: Armenia, Azerbaijan, Belarus, Bulgaria, Estonia, Georgia, Kazakhstan, Kyrgyzstan, Latvia, Lithuania, Republic of Moldova, Romania, Russian Federation, Tajikistan, Turkey, Turkmenistan, Ukraine and Uzbekistan (58).

Table A1.1 Monitoring framework for follow-up of the TB action plan for the WHO European Region, 2023–2030

Intervention area	Indicator	WHO/EURO baseline (2020)	Milestones (2025)	Targets (2030) ¹	Assessment frequency	Data source	Analysis layers	Monitoring mechanism ²	Indicator definition	Indicator level	
1. INTEGRATED, PEOPLE-CENTRED CARE AND PREVENTION											
1.A People at the centre: a shared approach on partnerships with PHC, public health and civil society and communities for united action											
1. A	1	Number of Member States with adopted standards and operational procedures for CSOs in the provision of psychosocial support services to ensure treatment adherence for people with TB (E)	N/A	≥60 %	TBD	Annual	Special surveys	HPC	Desk review	Number of Member States with adopted standards and operational procedures for CSOs in the provision of psychosocial support services to ensure treatment adherence for people with TB	Output
1. A.	2	Number of Member States with adopted procedures of subcontracting mechanisms under the state funds or other relevant funding	N/A	≥60 %	TBD	Annual	Special surveys	HPC	Desk review	Number of Member States with adopted procedures of subcontracting mechanisms under the state funds or other relevant	Output

		mechanisms for CSOs in the provision of psychosocial support and active case-finding services for people with TB (E)								funding mechanisms for CSOs in the provision of psychosocial support and active case-finding services for people with TB	
1.B		Comprehensive TB prevention, including programmatic management of TB preventive treatment (PMTPT), infection prevention and control and vaccination against TB									
1. B	1	TB preventive treatment (TPT) coverage (%) among PLHIV (G)	80%	≥99 %	≥99%	Annual	WHO Global TB database	EUR HPC EU/EEA	Routine reporting	<p>Numerator: Total number of new HIV patients enrolled in TPT in a specified period</p> <p>Denominator: Total number of new HIV patients eligible for TPT in the specified period</p>	Output
1. B	2	TPT coverage (%) in childhood TB contacts aged <5 years (G)	30%	≥90 %	≥95%	Annual	WHO Global TB database	EUR HPC EU/EEA	Routine reporting	<p>Numerator: Total number of child TB contacts age <5 years enrolled in TPT in the specified period</p> <p>Denominator: Estimated number of child TB contacts eligible for TPT in the specified period</p>	Output
1.C		Systematic screening for TB disease in targeted populations									

1. C	1	Coverage of contacts with systematic screening for active TB (G)	98%	≥90 %	≥90%	Annual	WHO Global TB database	EUR HPC EU/EE A	Routine reporting	<p>Numerator: Number of contacts of TB patients identified in the reporting year who were evaluated for active TB disease and TBI³</p> <p>Denominator 1: Number of contacts of active TB patients identified in the reporting year</p> <p>Denominator 2: Estimated number of household contacts of TB patients in the reporting year⁴</p>	Output
1.D		Early diagnosis of all forms of tuberculosis and universal access to drug-susceptibility testing (DST), including the use of rapid tests									
1. D	1	Percentage of notified new and relapse TB patients tested using WHO-recommended rapid diagnostic tests (G)	72%	≥90 %	≥95%	Annual	WHO Global TB database	EUR HPC EU/EE A	Routine reporting	<p>Numerator: Number of new and relapse patients tested using a WHO-recommended rapid diagnostic (for example Xpert MTB/RIF) as the initial diagnostic test (regardless of test result)</p> <p>Denominator: Total number of new and relapse patients notified</p>	Output

1. D	2	Bacteriological confirmation: Percentage of new and relapse pulmonary TB patients who are bacteriologically confirmed (E)	67%	>90 %	>90%	Annual	WHO Global TB database	EUR HPC EU/EEA	Routine reporting	Numerator: Number of new and relapse bacteriologically confirmed pulmonary TB cases (smear positive or culture positive or positive by WHO-recommended rapid diagnostics test) during the reporting period Denominator: Number of notified new and relapse pulmonary TB cases (bacteriologically confirmed plus clinically diagnosed) during the reporting period	Output
1. D	3	Testing for drug resistance: Percentage of people diagnosed with bacteriologically confirmed TB who had a documented susceptibility test result for rifampicin (G)	92%	100 %	100%	Annual	WHO Global TB database	EUR HPC EU/EEA	Routine reporting	Numerator: Number of patients with DST results for at least rifampicin among bacteriologically confirmed TB patients ⁵ Denominator: Total number of bacteriologically confirmed TB patients	Output
1. D	4	Testing for additional drug resistance: Percentage of people with RR-TB who had a	94%	100 %	100%	Annual	WHO Global TB database	EUR HPC	Routine reporting	Numerator: Number of patients diagnosed with RR-TB with susceptibility test	Output

		documented susceptibility test result for fluoroquinolones (E)						EU/EEA		results for fluoroquinolones Denominator: Total number of RR-TB patients	
1. D	5	RR/MDR-TB case-detection rate (%) (E)	94%	≥90 %	≥95%	Annual	WHO Global TB database /WHO TB burden estimates	HPC	Routine reporting/WHO estimates	Numerator: Total number of bacteriologically confirmed pulmonary RR/MDR-TB patients notified Denominator: Total number of estimated RR/MDR-TB patients among notified pulmonary TB	Output
1. D	6	TB case-detection rate (%) (E)	71%	≥95 %	≥95%	Annual	WHO Global TB database /WHO TB burden estimates	EUR HPC EU/EEA	Routine reporting/WHO estimates	Numerator: Total number of new and relapse TB patients notified Denominator: Total number of estimated new and relapse TB patients	Output
1. D	7	TB incidence rate per 100 000 population (E)	25	50% reduction compared with 2015	80% reduction compared with 2015	Annual	WHO TB burden estimates	EUR HPC EU/EEA	WHO estimates	Numerator: Total estimated number of new and relapse TB patients Denominator: Population number/100 000	Impact
1. D	8	RR-MDR/TB notification rate per 100 000 population (E)	N/A	1–5% annual	1–5% annual reduction ⁷	Annual	WHO Global TB database	HPC	Routine reporting	Numerator: Total number of bacteriologically confirmed RR-TB or	Outcome

				reduction 6						MDR-TB patients notified Denominator: Population number/100 000	
1.E		Equitable access to quality treatment and care for all people with TB, including those with DR-TB and TB comorbidities; and support for patients to facilitate treatment adherence									
1.E	1	Percentage of patients starting first-line TB treatment at the outpatient health care level (E)	To be calculated at the country level	Documented increase	Documented increase	2020 and 2025	WHO Global TB database	HPC	Routine reporting	Estimated percentage of patients that are receiving TB treatment at the ambulatory (outpatient) level (%) among patients starting first-line TB treatment Additional indicator: Estimated percentage of patients that are receiving TB treatment at the ambulatory (outpatient) level (%) among patients starting second-line TB treatment	Output
1.E	2	Percentage of notified RR/MDR-TB patients enrolled in treatment (G) (E)	100%	≥99%	≥99%	Annual	WHO Global TB database	EUR HPC EU/EEA	Routine reporting	Numerator: Total number of RR/MDR-TB patients enrolled into SLD treatment Denominator: Total number of RR/MDR-TB patients notified	Output

1. E	3	Treatment success rate (%) among all new and relapse TB patients (G)	77%	≥90 %	≥90%	Annual	WHO Global TB database	EUR HPC EU/EE A	Routine reporting	<p>Numerator: New and relapse TB patients notified in a specified period who were successfully treated</p> <p>Denominator: Total number of new and relapse TB patients notified in the same period</p>	Outcome
1. E	4	Treatment success rate (%) among the RR/MDR-TB treatment cohort (G)	56%	≥80 %	≥85%	Annual	WHO Global TB database	EUR HPC EU/EE A	Routine reporting	<p>Numerator: Number of bacteriologically confirmed RR/MDR-TB patients during the specified period that were successfully treated</p> <p>Denominator: Number of bacteriologically confirmed RR/MDR-TB patients that started on a prescribed TB treatment regimen during the specified period</p>	Impact
1. E	5	Treatment success rate (%) among pre-XDR-TB treatment cohort (G)	51%	≥75 %	≥80%	Annual	WHO Global TB database	EUR HPC EU/EE A	Routine reporting	<p>Numerator: Number of bacteriologically confirmed pre-XDR-TB patients during the specified period that were successfully treated</p> <p>Denominator: Number of</p>	Outcome

										bacteriologically confirmed pre-XDR-TB patients that started on a prescribed TB treatment regimen during the specified period. Additional disaggregation by XDR-TB treatment outcomes	
1. E	6	Total number of TB deaths (G)	21 000	75% reduction compared with 2015	90% reduction compared with 2015	Annual	WHO TB burden estimates	EUR HPC EU/EEA	WHO estimates	Estimated number of TB deaths (HIV-negative)	Impact
1. E	7	TB/HIV case-detection rate (%) (E)	68%	Close to 100%	Close to 100%	Annual	WHO Global TB database /WHO TB burden estimates	HPC	Routine reporting/WHO estimates	Numerator: Total number of notified TB/HIV coinfected patients among new and relapse TB patients in a specified period Denominator: Total number of estimated TB/HIV coinfected patients among new and relapse TB patients	Output
1. E	8	HIV testing coverage (%) (G)	93%	100%	100%	annual	WHO Global TB database	EUR HPC EU/EEA	Routine reporting	Numerator: Total number of notified new and relapse TB patients in a	Output

										specified period with reported HIV status Denominator: Total number of notified new and relapse TB patients in the specified period	
1. E	9	Percentage of HIV positives among new and relapse TB patients with documented test results (E)	15%	Decrease	Decrease	annual	WHO Global TB database	EUR HPC EU/EEA	Routine reporting	Numerator: Total number of notified new and relapse TB patients in a specified period who are HIV-positive Denominator: Total number of notified new and relapse TB patients in the specified period with documented HIV test results	Output
1. E	10	ART coverage (%) among TB/HIV patients (E)	74%	Close to 100%	Close to 100%	annual	WHO Global TB database	EUR HPC EU/EEA	Routine reporting	Numerator: Total number of notified new and relapse TB/HIV patients in a specified period who are enrolled in ART ⁸ Denominator: Total number of notified new and relapse TB patients in the specified period who are HIV-positive	Output
1. E	11	Screening of TB patients for mental and substance use disorders (E)	N/A	Close to 100%	Close to 100%	annual	Special surveys	EUR HPC EU/EEA	Desk review	Numerator 1: Number of new and relapse TB patients screened for mental disorders (using	Output

										WHO-recommended assessment tools) Numerator 2: Number of new and relapse TB patients screened for substance use disorders Denominator: Total number of notified new and relapse TB patients in the specified period	
2. BOLD POLICIES AND SUPPORTIVE SYSTEMS											
2.A	Governance and leadership										
2.A	1	Number of Members States that have a TB control strategy document publicly available that includes targets for reduction in TB mortality and incidence in line with the regional and global targets set in the resolution WHA67.1 and EUR/RC70/RX (E)	N/A			cumulative 2020 – 2025	Special surveys	EUR HPC EU/EEA	Desk review	Method of measurement: review (53 Member States, this includes the example of TB control measures integrated in overall strategy or standalone document)	Output
2.B	Health finance and universal health coverage										
2.B	1	Percentage of TB-affected households that experience catastrophic costs due to TB (G)	N/A	0%	0%	Survey conducted betw	Special Survey	HPC	Desk review	Source: TB catastrophic cost surveys	Impact

						een 2020 – 2025						
2.C		Health workforce including community health workers										
2. C	1	Proportion of people with TB found through active case-finding activities implemented through CSOs (E)	N/A	≥40 %	TBD	annual	Special survey/WHO Global TB database	HPC	Desk review	<p>Numerator: Number of people with TB from key affected population referred by community volunteers/NGOs for TB diagnosis and treatment</p> <p>Denominator: Total number of people with TB notified during the same period</p>	Output	
2. C	2	Proportion of people with TB who started TB treatment and who received any form of treatment adherence support from CSO (including psychosocial support) (E)	N/A	≥60 %	TBD	annual	Special survey/WHO Global TB database	HPC	Desk review	<p>Numerator: number of people with TB who started TB treatment and who received any form of treatment adherence support from CSO (including psychosocial support)</p> <p>Denominator: Total number of people with TB started treatment during the same period</p>	Output	

2.D		Strategic information and digital health									
2.D	1	Proportion of individuals who received TB treatment and care using digital adherence technologies (e.g. video-supported treatment of TB) (E)	N/A	≥30 %	≥40%	annual	Special surveys	HPC	Desk review	Numerator: Number of patients using digital adherence technologies (e.g. video-supported treatment) during the period of outpatient treatment and care Denominator: Total number of patients in outpatient care who completed treatment	Outcome
3. INTENSIFIED RESEARCH AND INNOVATION											
3.A		Intensified research and innovation									
3.A	1	Number of Member States with a standing alone national TB research agenda or research priorities integrated in the national TB strategic plans or relevant policies (E)	N/A			Cumulative 2020 – 2025	Special surveys	EUR HPC EU/EEA	Desk review	Method of measurement: desk review	Output

Note: WHO European Region-specific indicators are marked (E); indicators which are also included in the Global End TB strategy are marked (G).

ART: antiretroviral therapy; CSO: civil society organization; DR: drug-resistant; DST: drug-susceptibility testing; EEA: European Economic Area; EU: European Union; EUR: WHO European Region; HPC: 18 high priority countries; MDR: multidrug-resistant; mSTR: modified fully oral shorter treatment regimens; NGO: nongovernmental organization; PHC: primary health care; PLHIV: people living with HIV; RR: rifampicin-resistant; SLD: second-line drug; TB: tuberculosis; TBI: tuberculosis infection; TPT: tuberculosis preventive treatment; XDR: extremely drug-resistant.

¹Targets to be revised in 2024.

²Some of data for “desk review” assessment are collected through routine reporting to European level and analysed in this report.

³According to the national guidelines.

⁴For measuring the coverage of the contact investigation (taken from United Nations, Department of Economic and Social Affairs, Population Division. Household Size and Composition Around the World).

⁵*Including results from molecular tests (e.g. WHO-recommended rapid diagnostic test) as well as conventional phenotypic DST results.*

⁶*Any documented reduction is acceptable.*

⁷*Any documented reduction is acceptable.*

⁸*Within 8 weeks of starting TB treatment.*

Annex 2 Mathematical modelling to inform and track progress on reaching the TB Action Plan targets

This is a detailed description of the structure of the TB transmission model created to inform and track progress made on reaching the TB Action Plan targets. The model's mathematical governing equations are provided along with descriptions of the procedures used for calibrating the model parameters against relevant TB data from the WHO European Region.

Model structure

The following structure describes the stages of disease and the cascade of TB care relevant in the WHO European Region context. The schematic in **Fig. A2.1** shows the transitions into different stages of the TB natural history and cascade of care. A descriptions of the model's state variables and can be found in **Table A2.1**.

Fig. A2.1 Model structure

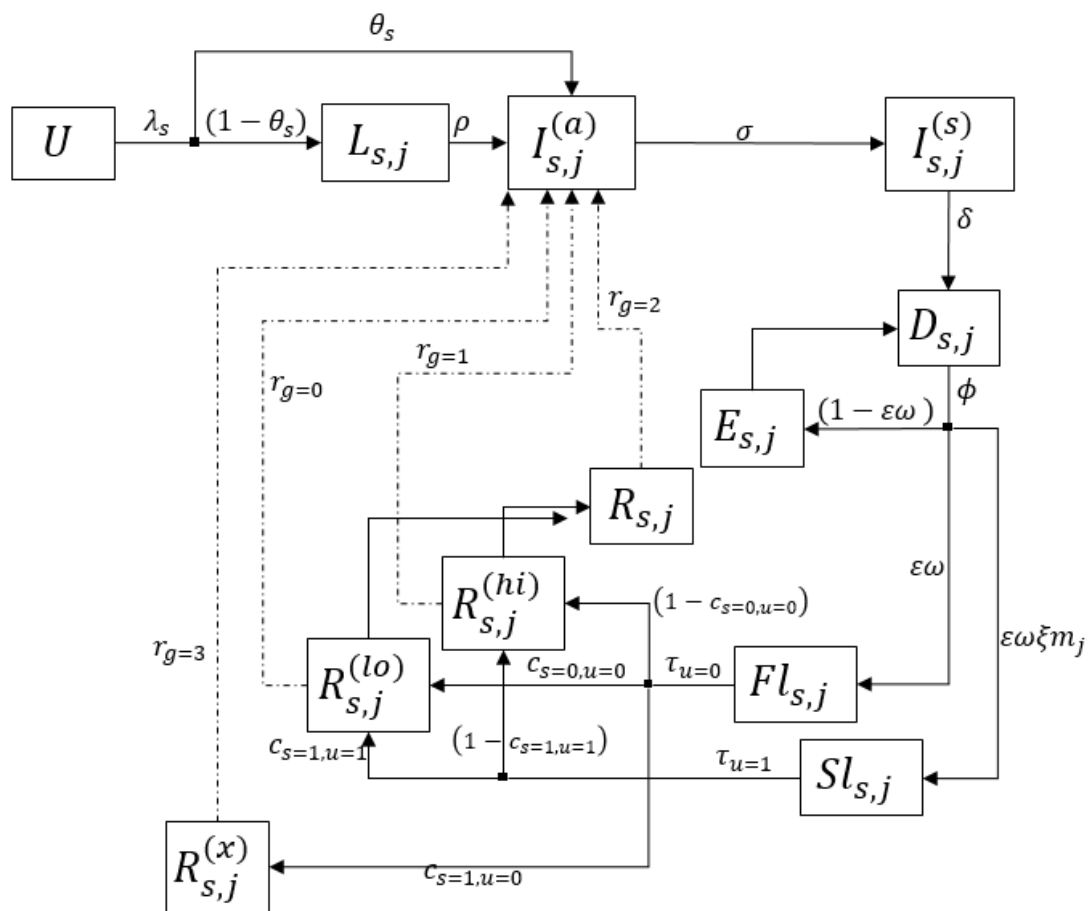

Note: The model captures the acquisition and spread of DR-TB (drug resistance status denoted by s in the diagram) and captures the differential burden of DR-TB between new and previously treated cases. Arrows represent transitions between states, annotated with relevant per capita hazard rates. Definitions of state variables (shown in boxes) are in Table A2.1.

Table A2.2 Descriptions of the model's state variables and subindices

Model stage	Description
U	Uninfected
$L_{s,j}$	Latent infection
$I_{s,j}^{(a)}$	Active TB, asymptomatic (not reporting symptoms)
$I_{s,j}^{(s)}$	Active TB, symptomatic
$D_{s,j}$	Sought TB care and awaiting diagnosis
$FL_{s,j}$	Undergoing TB first-line treatment
$SL_{s,j}$	Undergoing TB second-line treatment
$E_{s,j}$	Between care-seeking episodes (following missed diagnosis or initial loss to follow-up)
$R_s^{(lo)}$	Recovered, low relapse risk (following treatment completion)
$R_s^{(hi)}$	Recovered, "high" relapse risk (following treatment default)
R_s	Stabilized relapse risk, >2 years after treatment
$R_s^{(x)}$	Recovered MDR-TB after first-line treatment, very high relapse risk (following treatment completion)
Subscript	Description
s	Denotes the strain of TB (with $s=0$ for DS and $s=1$ for DR)
j	Indicates history TB treatment, where $j=0$ for new and $j=1$ for retreated

DS: drug-susceptible; DR: drug-resistant; MDR-TB: multidrug-resistant tuberculosis; TB: tuberculosis.

Model equations

The following ordinary differential equations correspond to the model compartments described in **Fig. A2.1**. The model was programmed as a deterministic compartmental model and solved using MATLAB®, and R programming language.

Uninfected

$$\frac{dU(t)}{dt} = Z - U(t)\lambda_s(t) - U(t)\mu$$

Equation 1,

Latent

$$\frac{dL_{s,j}(t)}{dt} = \begin{cases} (1 - \theta_s)U(t)\lambda_s(t) - L_{s,j}(t)(\mu + \rho), & \text{for } j = 0 \\ 0, & \text{for } j = 1 \end{cases}$$

Equation 2

Active TB asymptomatic

$$\frac{dI_{s,j}^{(a)}(t)}{dt} = \begin{cases} \theta_s U(t)\lambda_s(t) + L_{s,j}(t)\rho + R_{s,j}(t)r_0 - I_{s,j}^{(a)}(t)(\mu^{(tb)} + \sigma), & \text{for } j = 0 \\ \begin{cases} R_s(t)r_0 + R_s^{(lo)}(t)r_1 + R_s^{(hi)}(t)r_2 \\ + R_s^{(x)}(t)r_3 - I_{s,j}^{(a)}(t)(\mu^{(tb)} + \sigma), \end{cases} & \text{for } j = 1 \end{cases}$$

Equation 3

Active TB symptomatic

$$\frac{dI_{s,j}^{(s)}(t)}{dt} = I_{s,j}^{(a)}(t)\sigma - I_{s,j}^{(s)}(t)(\mu^{(tb)} + \delta)$$

Equation 4

Initial presentation for care

$$\frac{dD_{s,j}(t)}{dt} = I_{s,j}^{(s)}(t)\delta\eta + E_{s,j}(t)\gamma\eta - D_{s,j}(t)(\mu^{(tb)} + \phi)$$

Equation 5

Diagnosis and first-line treatment initiation

$$\frac{dFl_{s,j}(t)}{dt} = \begin{cases} D_{s,j}(t)\phi\varepsilon\omega - Fl_{s,j}(t)(\mu + \tau_0 + \chi_s + \varrho), & \text{for } s = 0 \\ D_{s,j}(t)\phi\varepsilon\omega(1 - m_j) + Fl_{0,j}(t)\varrho - Fl_{s,j}(t)(\mu + \tau_0 + \chi_s), & \text{for } s = 1 \end{cases}$$

Equation 6

Diagnosis and second-line treatment initiation

$$\frac{dSl_{s,j}(t)}{dt} = \begin{cases} 0, & \text{for } s = 0 \\ \begin{cases} D_{s,j}(t)\phi\varepsilon\omega\xi m_j + Fl_{s,j}(t)\tau_0(1 - c_{s,0})\xi \\ - Sl_{s,j}(t)(\mu + \tau_1 + \chi_s), \end{cases} & \text{for } s = 1 \end{cases}$$

Equation 7

Missed diagnosis and initial loss to follow-up

$$\frac{dE_{s,j}(t)}{dt} = \begin{cases} D_{s,j}(t)\phi(1 - \varepsilon\omega) - E_{s,j}(t)(\psi + \gamma), & \text{for } s = 0 \\ \begin{cases} D_{s,j}(t)\phi(1 - \varepsilon\omega) + Fl_{s,j}(t)\tau_0(1 - c_{s,0})(1 - \xi) \\ + Sl_{s,j}(t)(\tau_1(1 - c_{s,1}) + \chi_s) - E_{s,j}(t)(\psi + \gamma); \end{cases} & \text{for } j = 1 \text{ and } s = 1 \end{cases}$$

Equation 8

Recovery after curative treatment (low relapse)

$$\frac{dR_s^{(lo)}(t)}{dt} = \begin{cases} \sum_j (Fl_{s,j}(t)\tau_0c_{s,0}) - R_s^{(lo)}(t)(\mu + r_1 + \varsigma), & \text{for } s = 0 \\ \sum_j (Sl_{s,j}(t)\tau_1c_{s,1}) - R_s^{(lo)}(t)(\mu + r_1 + \varsigma) & \text{for } s = 1 \end{cases}$$

Equation 9

DR-TB, relapse following temporary cure from first-line (FL) treatment

$$\frac{dR_1^{(x)}(t)}{dt} = \sum_j (Fl_{1,j}(t)\tau_0c_{1,0}) - R_1^{(x)}(t)(\mu + r_3)$$

Equation 10

DS-TB, relapse following default from FL treatment

$$\frac{dR_0^{(hi)}(t)}{dt} = \sum_j (Fl_{0,j}(t)\chi_0) - R_0^{(hi)}(t)(\mu + r_2 + \varsigma)$$

Equation 11

Recovered stabilized

$$\frac{dR_s(t)}{dt} = \varsigma (R_s^{(hi)}(t) + R_s^{(lo)}(t)) - R_s(t)(\mu + r_0)$$

Equation 12

Force of infection

$$\lambda_s(t) = \begin{cases} \frac{\beta_{ds} \left\{ \sum_j \left[\sum_s (Ia_{s,j}(t) + Is_{s,j}(t)) \right] + \kappa \sum_j \left[\sum_s (D_{s,j}(t) + E_{s,j}(t)) \right] \right\}}{N(t)}, & \text{for } s = 0 \\ \frac{\beta_{mdr} \left\{ \sum_j \left[\sum_s (Ia_{s,j}(t) + Is_{s,j}(t)) \right] + \kappa \sum_j \left[\sum_s (D_{s,j}(t) + E_{s,j}(t) + Fl_{s,j}(t)) \right] \right\}}{N(t)}, & \text{for } s = 1 \end{cases}$$

Equation 13

where $N(t)$ represents the total population at time t . Subindex s denotes the strain of TB (with $s=0$ for DS and $s=1$ for DR).

Subindex j indicates history of TB treatment, where $j=0$ for new and $j=1$ for retreated. Subindex u indicates the line of TB therapy, taking values of 0 and 1 for first-line and second-line therapy, respectively. Subscript g refers to different levels of relapse. See **Table A2.1** for descriptions of the model's state variables and subindices used in the equations. Model parameters can be found in a similar model developed for Moldova (59).

Model calibrations

We used a Bayesian framework and a Markov-Chain Monte Carlo (MCMC) method to calibrate the transmission model using the European regional data collected by WHO as target data (44) (**Table A2.2**).

Table A2.3 Target data from the WHO European Region. Programmatic and estimated data

Year	All TB incidence per 100 000	MDR-TB incidence per 100 000	TB mortality rate per 100 000	TB notification rate per 100 000	Proportion of incidence that is MDR-TB (%)
2015	33	–	–	29	–
2016	–	–	3	–	–
2017	30	–	–	26	–
2018	–	–	–	–	–
2019	26	7.5	–	23	17
2020	25	–	2.3	18	–

MDR-TB: multidrug-resistant tuberculosis; TB: tuberculosis.

Fig.A2.2 gives a graphical view of the model fit to data. In addition, MCMC diagnostics presented as parameter trace plots show convergence (Fig.A2.3), and a stationary distribution (Fig.A2.4). Further model projections were produced by sampling from this distribution and reproducing model output.

Fig.A2.2 Model fits for a European Regional TB model

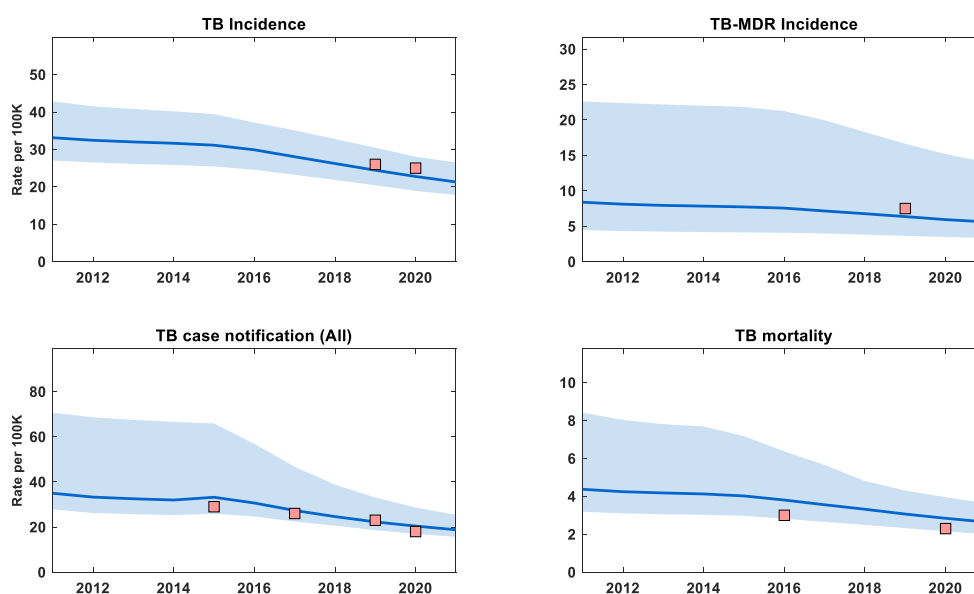

Note: Clear blue bands show 95% credible intervals, as obtained from the posterior distribution. Red squares show the regional data. Medians shown by solid lines.

Fig.A2.3 Trace plots for the parameter samples during calibration

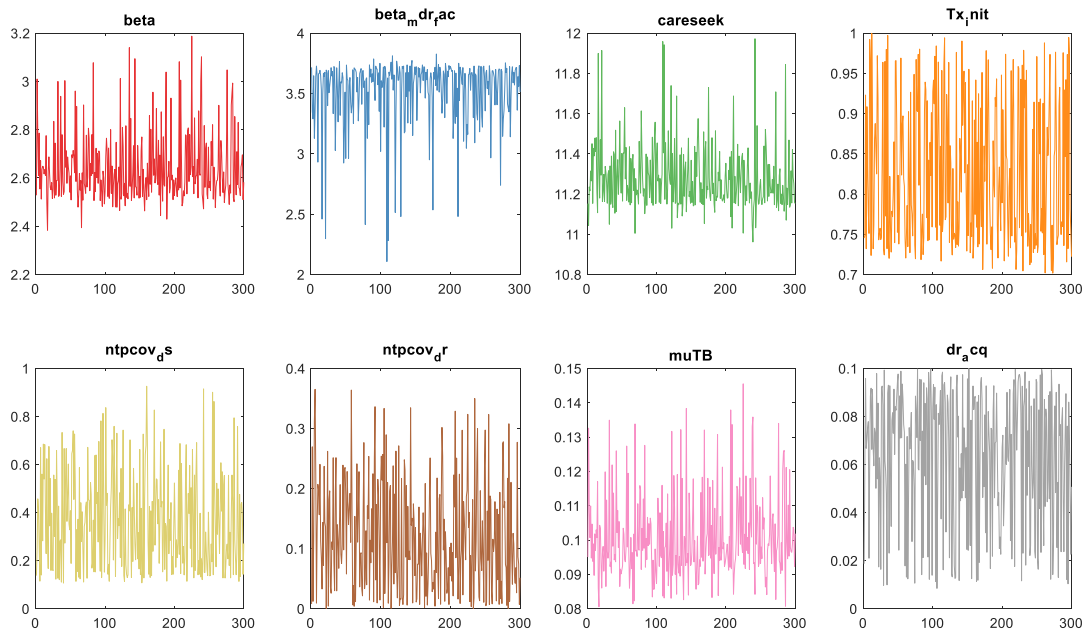

Note: The shape of the trace denotes good convergence to a stationary distribution, and an overall good fit of the model to data. In the upper row, from left to right, trace plots for transmission probabilities Beta for DS TB, Beta_{mdr} for acquired DR TB, care-seeking delays (careseek), and Treatment initiation rates (TX_{init}). In the lower row, trace plots for parameters controlling the initial coverage (1970s–1990s) on DS and DR diagnosis and treatment coverage ($\text{ntpcov}_{\text{ds}}$ and $\text{ntpcov}_{\text{dr}}$), μTB parameter for case fatality rate of untreated TB after 2 years, and dr_{acq} for the fraction of first-line (FL) TB treatment that results in resistance acquisition.

Fig.A2.4 Posterior distribution of calibrated parameters

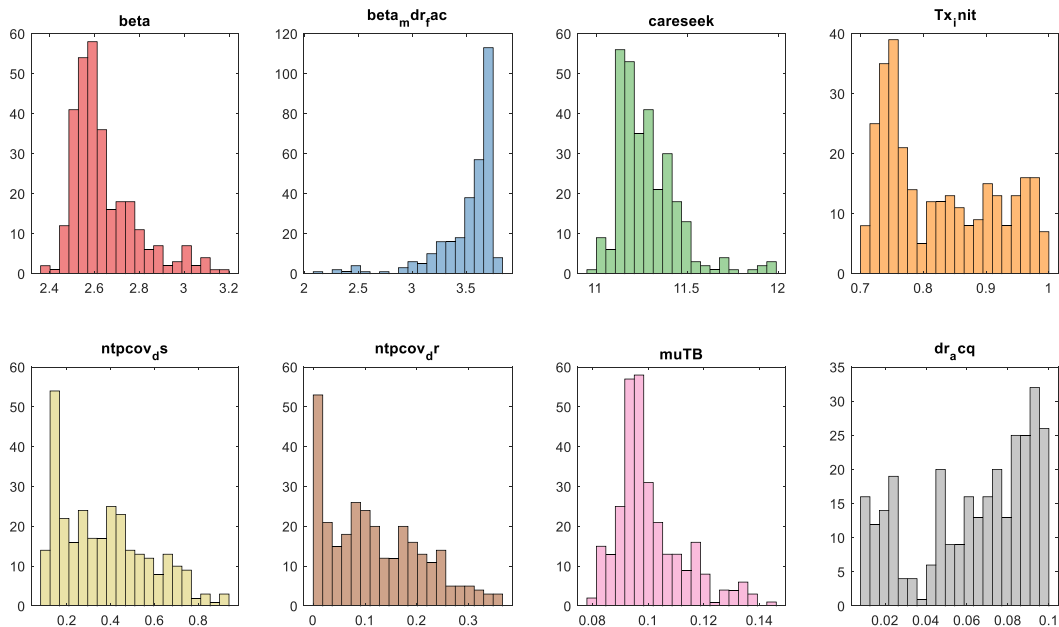

Note: Histograms reflect the posterior distributions of the parameters calibrated during model fitting. In the upper row, from left to right, trace plots for transmission probabilities Beta for DS TB, Beta_{mdr} for acquired DR TB, care-seeking delays (careseek), and Treatment initiation rates (TX_{init}). In the lower row, trace plots for parameters controlling the initial coverage (1970s–1990s) on DS and DR diagnosis and treatment coverage ($\text{ntpcov}_{\text{ds}}$ and $\text{ntpcov}_{\text{dr}}$), μTB parameter for case fatality rate of untreated TB after 2 years, and dr_{acq} for the fraction of first-line (FL) TB treatment that results in resistance acquisition.

Model interventions

Within this calibrated model framework, we projected TB incidence and mortality until 2035, and compared incidence reductions against WHO's TB elimination threshold. The disruptions in TB detection and TB treatment arising from the COVID-19 pandemic are introduced in 2020–2021, and a 24% reduction or disruption of diagnostic and TB treatment, relative to pre-pandemic levels, is assumed.

Table A2.3 describes the interventions simulated. These interventions were simulated to take effect from 2021, until 2025, with a 3-year linear scale-up. A so-called silver bullet intervention, in the form of effective vaccination, is introduced in 2027 with a similar 3-year linear scale-up to reach target coverage.

Table A2.4 Modelled interventions along the TB cascade of care with targets for 2021–2025

Cascade level	Intervention	Model intervention	Target
TB treatment	<ul style="list-style-type: none"> New adherence tools to improve adherence and manage toxicities Increase availability of TB treatment given a previous TB diagnosis Increase fraction of second-line treatment using FQ 	<ol style="list-style-type: none"> 1. Improve treatment success rate 2. Increase treatment coverage 3. Introduce shorter, all oral treatment regimen 	<ol style="list-style-type: none"> 1. >95% 2. >90% 3. >50%
TB diagnosis	<ul style="list-style-type: none"> Increase the proportion of new TB diagnosis that undergo DST before treatment start Increase proportion of diagnostic attempts performed using WHO recommended rapid testing 	<ol style="list-style-type: none"> 4. Increase DST 5. Increase coverage with rapid diagnostics 	<ol style="list-style-type: none"> 4. >90% 5. >95%
Pre-care-seeking	<ul style="list-style-type: none"> Reduce barriers to access TB care services Reduce prevalence of undetected TB 	<ol style="list-style-type: none"> 6. Pre-care-seeking delay 7. Active case-finding 	<ol style="list-style-type: none"> 6. 25% 7. 30%
TB prevention	<ul style="list-style-type: none"> Increase the number of household contacts of bacteriologically confirmed cases on TPT 	<ol style="list-style-type: none"> 8. Tuberculosis preventive therapy 	<ol style="list-style-type: none"> 8. >30%
Silver bullet	<ul style="list-style-type: none"> Effective vaccine (95%) preventing progression from latent to active TB (no transmission blocking assumed) 	<ol style="list-style-type: none"> 9. Reduce reactivation by vaccination 	<ol style="list-style-type: none"> 9. 50% (coverage)

FQ: Fluoroquinolones; TB: tuberculosis; TPT: tuberculosis preventive treatment; WHO: World Health Organization.